

# ODIS

IRRIGATION EQUIPMENT LTD.

## ODISMATIC® HYDRAULIC FILTERS

### SERIES 851/851B

#### APPLICATIONS

- Used as an economic compact Automatic Screen Filter in places without electricity
- The filter contains a Hydraulically operated Collector with Suction Nozzles to ensure continuous trouble free operation.
- For: Irrigation, Water recycling and Industry.



ODIS Filtration *is The Heart* of Every Irrigation System

## DESCRIPTION

The **Odismatic® Hydraulic Filter Model 851/851B** are an automatic self cleaning screen filter. The filter uniqueness lies in the automatic suction system for cleaning the screen. This system is operated by the inline water pressure without interfering to the filtration process. The screen cleaning process is short, efficient, saves water and leaves the screen clean.

Dirty water enters the filter through the inlet port, passing through the fine screen (1) and flows out through the outlet port. The dirt particles stopped on the screen (1) create a "cake" of sediment. This "cake" improves filtration efficiency as it performs a finer filtration. The sediments accumulated on the screen, create a differential pressure across the screen. The differential pressure rises until the predetermined value is reached [normally 0.5 bar (7.5 psi)].

A pressure switch activates the self cleaning process. A timer backup guarantees that the time passed from the last self cleaning process will not be longer than the preset value determined by the user.

On a flushing command, the flushing valve (4) opens to the atmosphere and creates pressure drop in the motor chamber (5), causing the dirt to be sucked in from the screen by the nozzles (2). This pressure drop also moves the piston (7) and the collector (3) in a linear movement. In addition, the hydraulic motor (6) rotates the collector.

These two processes performed simultaneously create a helical movement of the nozzles so they "cover" the whole screen surface, enabling complete and effective cleaning of the screen. The entire process takes approximately 6-16 seconds (according to filter model), upon completion of the cleaning process the filter returns to its initial position.

This self cleaning flushing cycle can be initiated by DP switch, timer backup or manually.

Available in the following inlet sizes: ¾", 1", 1½", 2", 3", 4", 6", 8".

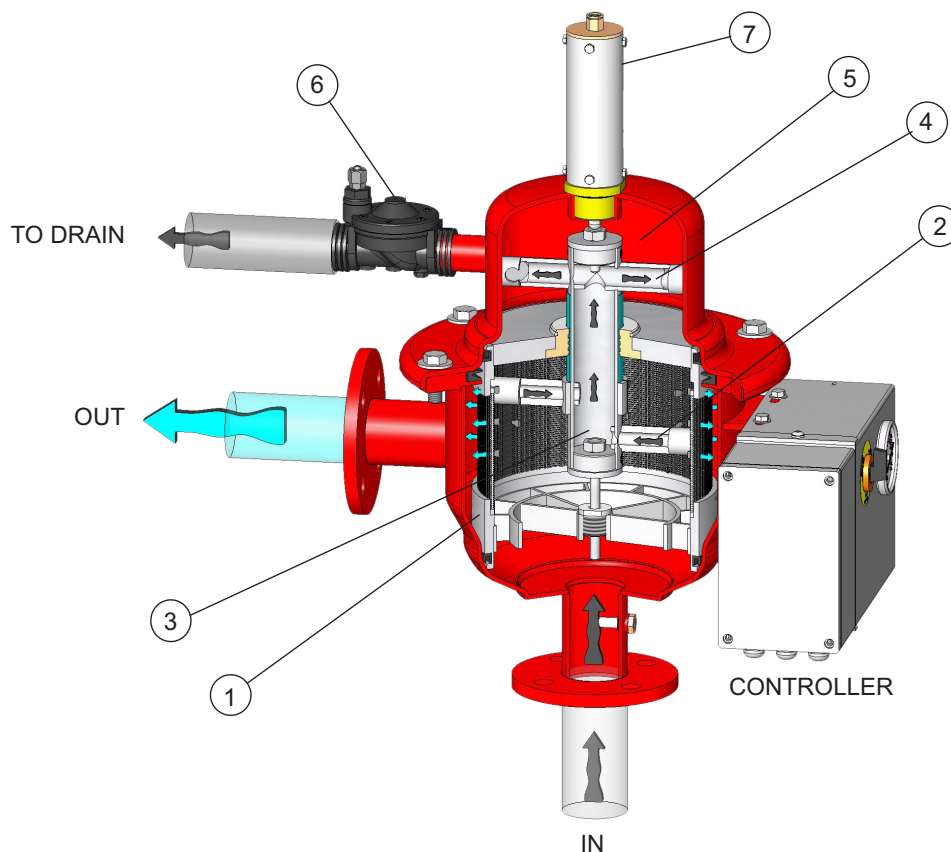

**Dimensions & Weight** Metric Units/ U.S. Units

Model	B	D	A *		E *		H *		T *		Weight	
	inch	inch	mm	inch	mm	inch	mm	inch	mm	inch	kg	lbs
85107M	¾"	6"	150	5.9	410	16	500	18	155	6.1	11	24
85101M	1"	6"	150	5.9	410	16	500	18	155	6.1	11	24
851B15M	1½"	10"	188	7.4	540	21	560	22	175	6.9	25	55
851B15F	1½"	10"	230	9.1	540	21	600	24	220	8.7	26	57
851B02M	2"	10"	196	7.7	540	21	570	23	185	7.3	27	60
851B02F	2"	10"	230	9.1	540	21	600	24	220	8.7	28	62
851B03M	3"	10"	260	10.2	540	21	750	30	195	7.7	40	88
851B03F	3"	10"	280	11	540	21	770	31	220	8.7	41	90
851B04F	4"	10"	280	11	540	21	770	31	220	8.7	42	92
851B04LF	4"	10"	280	11	540	21	905	36	220	8.7	48	106
85106F	6"	12"	540	21.2	600	24	1310	52	320	12.6	65	143
85108F	8"	12"	700	27.6	600	24	1530	60	320	12.6	78	172

\* For victaulic connection decrease 5 mm / 0.15 inch from F model

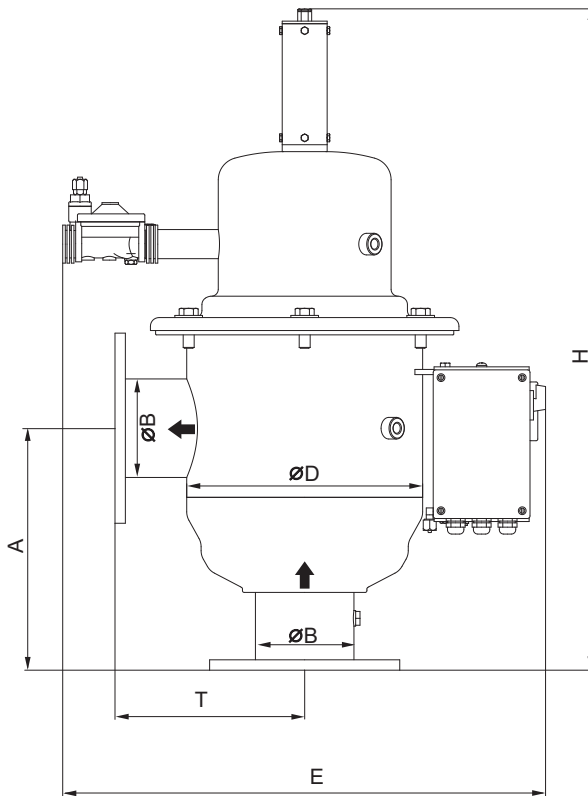

Models : 851B15 (1.5")  
 851B02 (2")  
 851B03 (3")  
 851B04 (4")  
 851B04L (4")  
 85106 (6")  
 85108 (8")

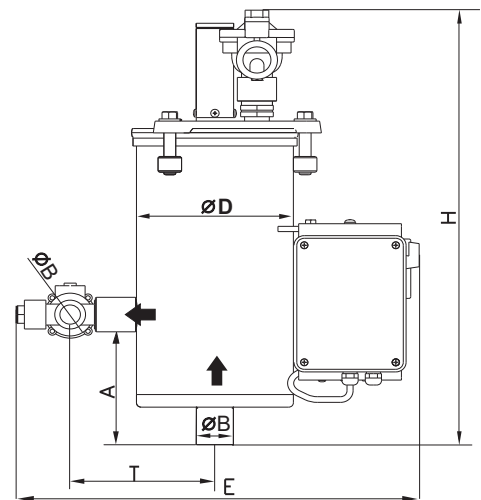

Models : 85107 (¾")  
 85101 (1")

## Screen Area & Recommended Flow Rates

Model	Inlet/Outlet diameter		Max. Flow Rate		Flushing Flow Rate		Screen Area			
	mm	inch	m <sup>3</sup> /h	U.S gpm	m <sup>3</sup> /h	U.S gpm	Sintered		P.V.C Housing	
							cm <sup>2</sup>	inch <sup>2</sup>	cm <sup>2</sup>	inch <sup>2</sup>
85107	20	¾"	4	18	2-3	9-13	---	---	320	50
85101	25	1"	7	31	2-3	9-13	---	---	320	50
851B15	40	1½"	15	66	4-5	17-22	1040	160	650	100
851B02	50	2"	25	110	4-5	17-22	1040	160	650	100
851B03	80	3"	40	170	4-5	17-22	1960	305	1250	195
851B04	100	4"	80	350	4-5	17-22	1960	305	1250	195
851B04L	100	4"	80	350	8-10	35-44	3520	545	2200	340
85106	150	6"	150	660	8-10	35-44	6550	1015	4100	635
85108	200	8"	300	1300	12-14	53-62	9100	1410	5700	885

- The max. flow rate refers to screens over 200 microns/less than 80 mesh, For a finer filtration degrees consult our representative.

## Stainless Steel Filter Screens

### Filtering Grades

Mesh Grade	Micron
40	400
50	300
80	200
100	150
120	120
150	100
200	80
300	50
500	30

- Fine screen – Multi layer stainless steel wire mesh sintered together or woven stainless steel wire mesh mounted on the inner surface of a P.V.C. cylinder.

### Technical Data

- Max. working pressure: 10 bar (150 psi)
- Min. working pressure for models - ¾", 1", 1½", 2", 3", 4": 1 bar (15 psi)  
Min. working pressure for models - 6", 8": 2 bar (30 psi)
- Suction system with nozzles operated by the water pressure, no electricity is required.
- Fine Screen: Multi layer stainless steel wire mesh sintered together or woven stainless steel wire mesh mounted on the inner surface of a P.V.C. cylinder, stops the fine dirt particles.  
Wide range of screens down to 30 micron
- Automatic self cleaning of the screen - activated by time elapsed or DP (differential pressure)
- Flushing controller operated by 6V DC battery.  
(AC controller is available upon request).

### Protective Coating

120 micron extra durable polyester, applied electrostatically and oven cured on a zinc phosphate layer for anti corrosion protection

### Pressure Relief Valve

A pressure relief valve must be inserted before the filtering installation if pressure is not controlled effectively.

- Each filter is designed and manufactured in order to achieve the highest standard of quality and finish.

**HEAD LOSS/ FLOW RATE**

**Metric Units**

**Head Loss \*\***

Model	Flow Rate Q (m <sup>3</sup> /h)													
	5	10	15	25	50	75	100	150	200	250	300	350	400	500
	Head Loss dP (bar)													
85107	0.15	0.59												
85101	0.08	0.31	0.69											
851B15		0.11	0.25	0.69										
851B02			0.07	0.21	0.83									
851B03					0.16	0.36	0.64							
851B04					0.07	0.15	0.26	0.59	1.04					
851B04L					0.05	0.11	0.19	0.43	0.76					
85106							0.06	0.13	0.23	0.35	0.51	0.69	0.90	
85108								0.04	0.08	0.12	0.17	0.23	0.30	0.47

**Head Loss/Flow Rate \*\***

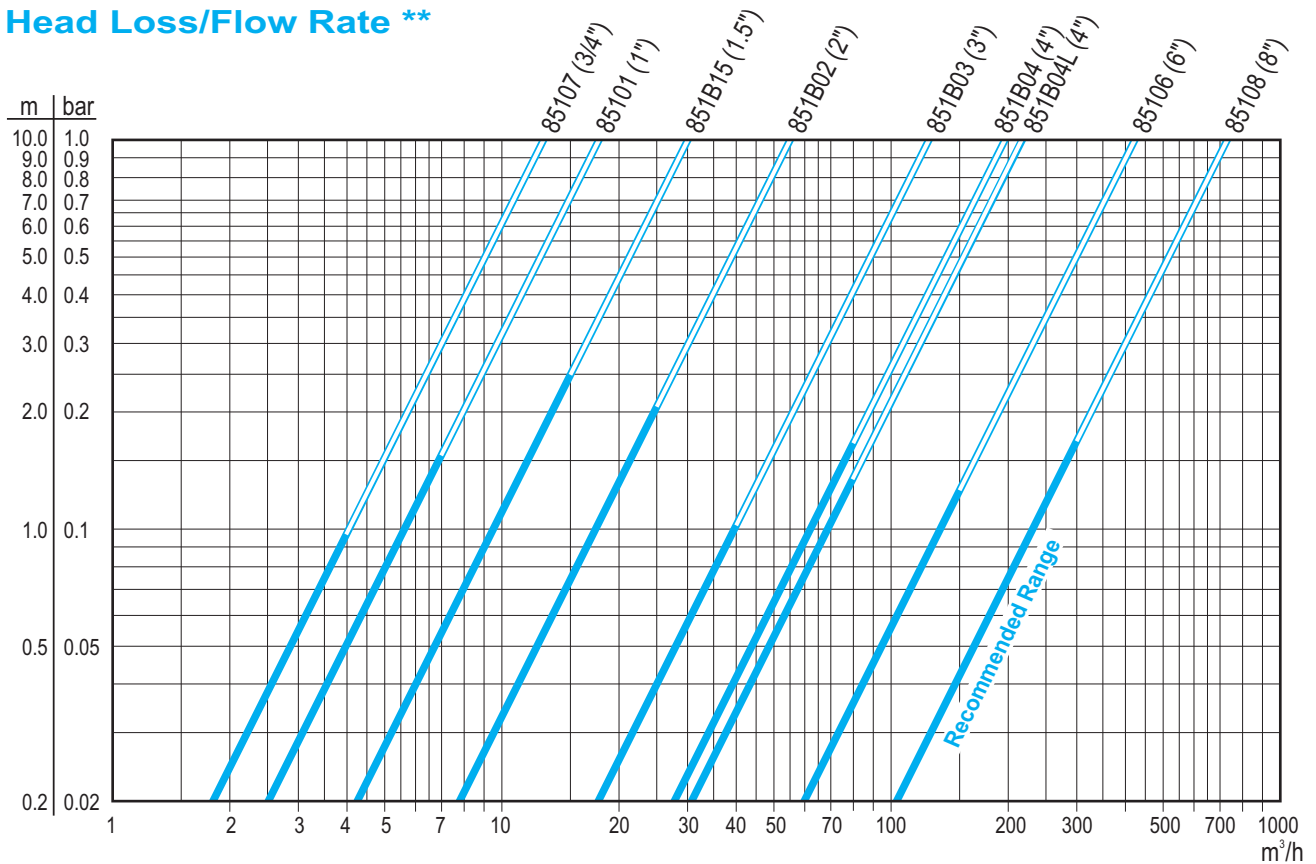

\*\* For a clean filter and 120 micron screen

■ 1 bar=100 kPa=1.02 kg/cm<sup>2</sup>=10.2 m (W.C)=14.5 psi

**HEAD LOSS/ FLOW RATE**

**U.S. Units**

**Head Loss \*\***

Model	Flow Rate Q (U.S. gpm)													
	25	50	75	100	150	200	250	300	350	400	500	750	1000	1500
	<b>Head Loss dP (psi)</b>													
85107	2.8	11.1												
85101	1.4	5.8	13.0											
851B15	0.5	2.1	4.7	8.3										
851B02		0.6	1.4	2.5	5.6	9.9	15.5							
851B03					1.1	1.9	3.0	4.3	5.9	7.7	12.0			
851B04						0.8	1.2	1.8	2.4	3.1	4.9	11.0		
851B04L						0.6	0.9	1.3	1.7	2.3	3.6	8.0		
85106									0.5	0.7	1.0	2.4	4.2	9.4
85108												0.8	1.4	3.2

**Head Loss/Flow Rate \*\***

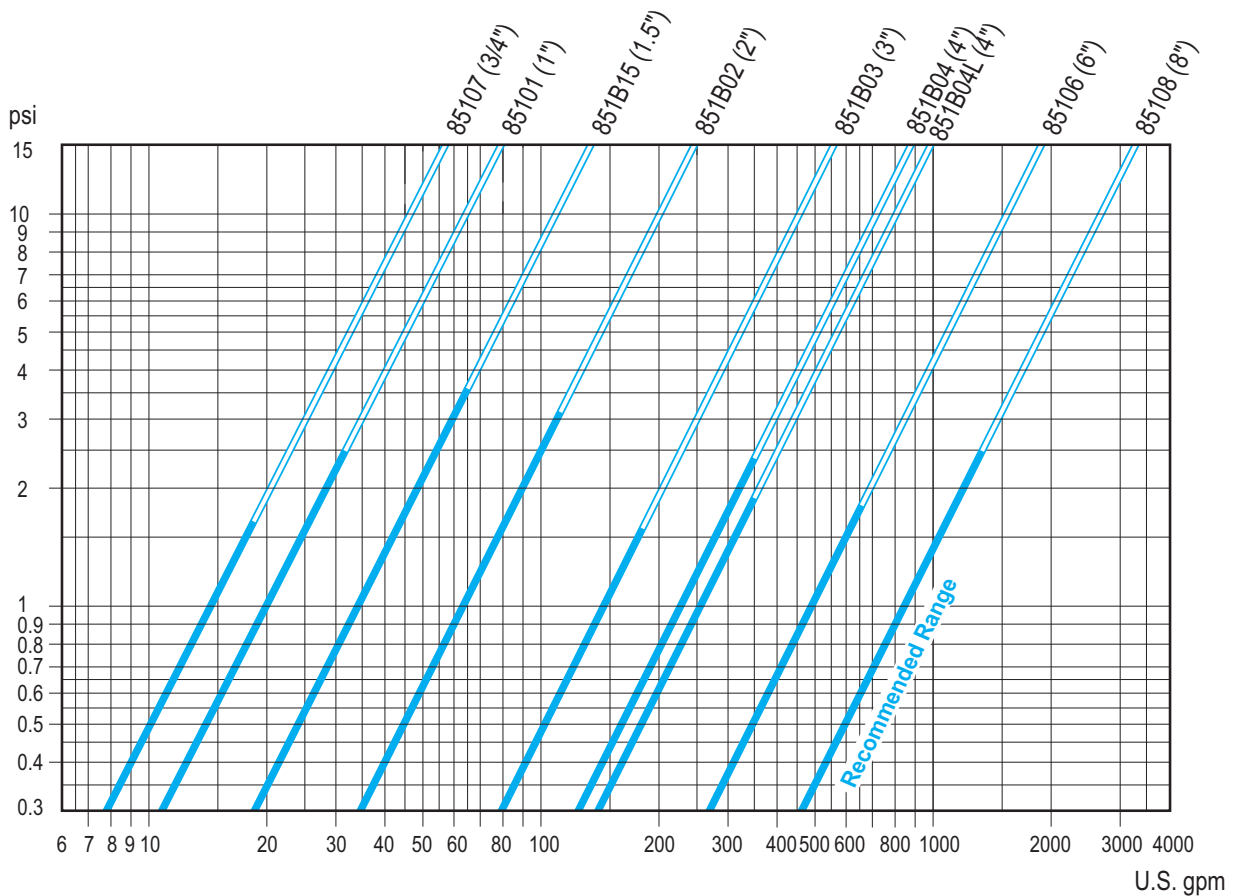

\*\* For a clean filter and 120 mesh screen

■ 1 psi=0.069 bar=6.9 kPa=0.07 kg/cm<sup>2</sup>=0.7 m (W.C)

**ILLUSTRATED PARTS BREAKDOWN**

NO.	DESCRIPTION
1	Filter Body
2	Fine Screen Assembly
3	Dirt Collector Assembly
4	Hydraulic Motor
5	Cover Gasket
6	Cover
7	Rinse Valve
8	Hydraulic Piston
9	Control Box

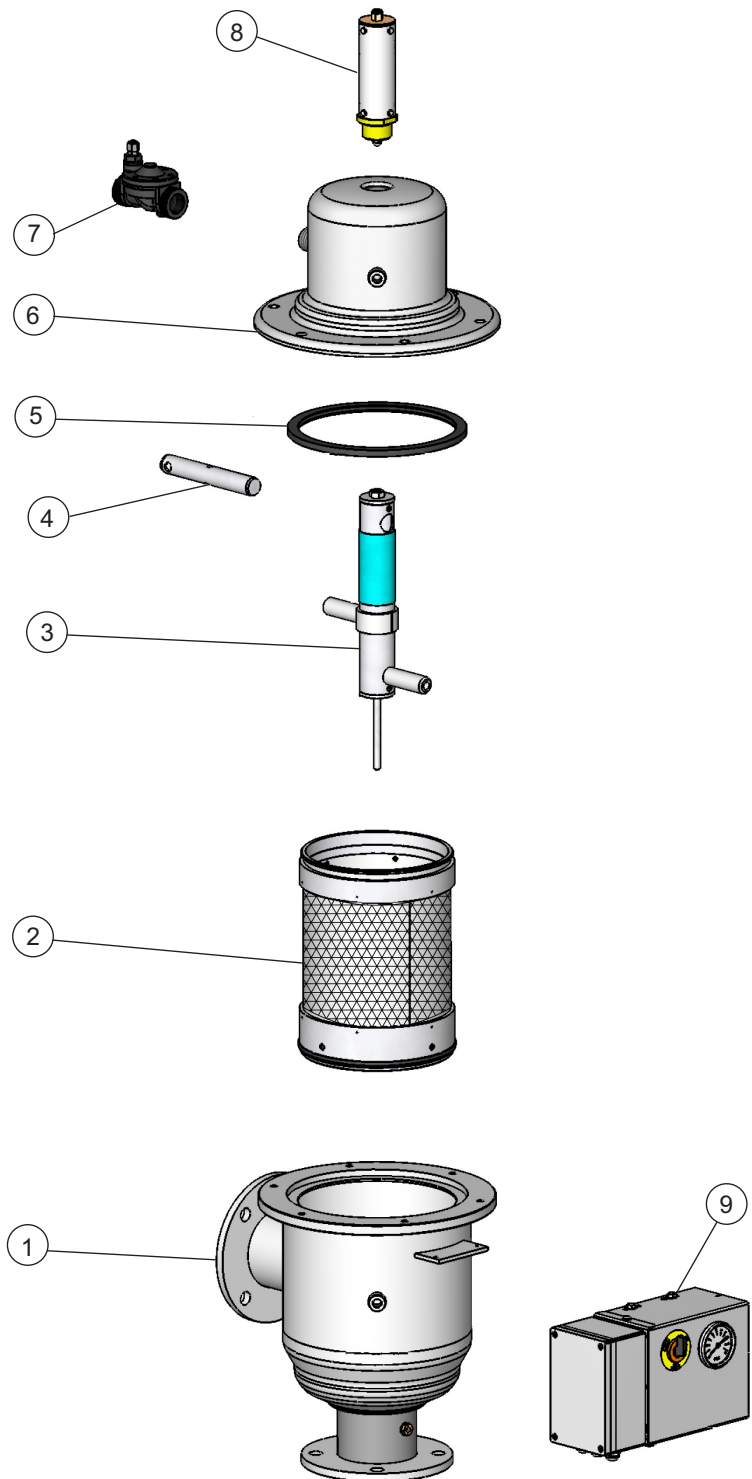

- Models:**  
**851B15 (1.5")**  
**851B02 (2")**  
**851B03 (3")**  
**851B04 (4")**  
**851B04L (4")**  
**85106 (6")**  
**85108 (8")**



**ILLUSTRATED PARTS BREAKDOWN**

NO.	DESCRIPTION
1	Filter Body
2	Fine Screen Assembly
3	Flushing Chamber
4	Dirt Collector Assembly
5	Hydraulic Motor
6	Cover Gasket
7	Cover
8	Rinse Valve
9	Hydraulic Piston
10	Control Box
11	Outlet Valve
12	Inner Gasket

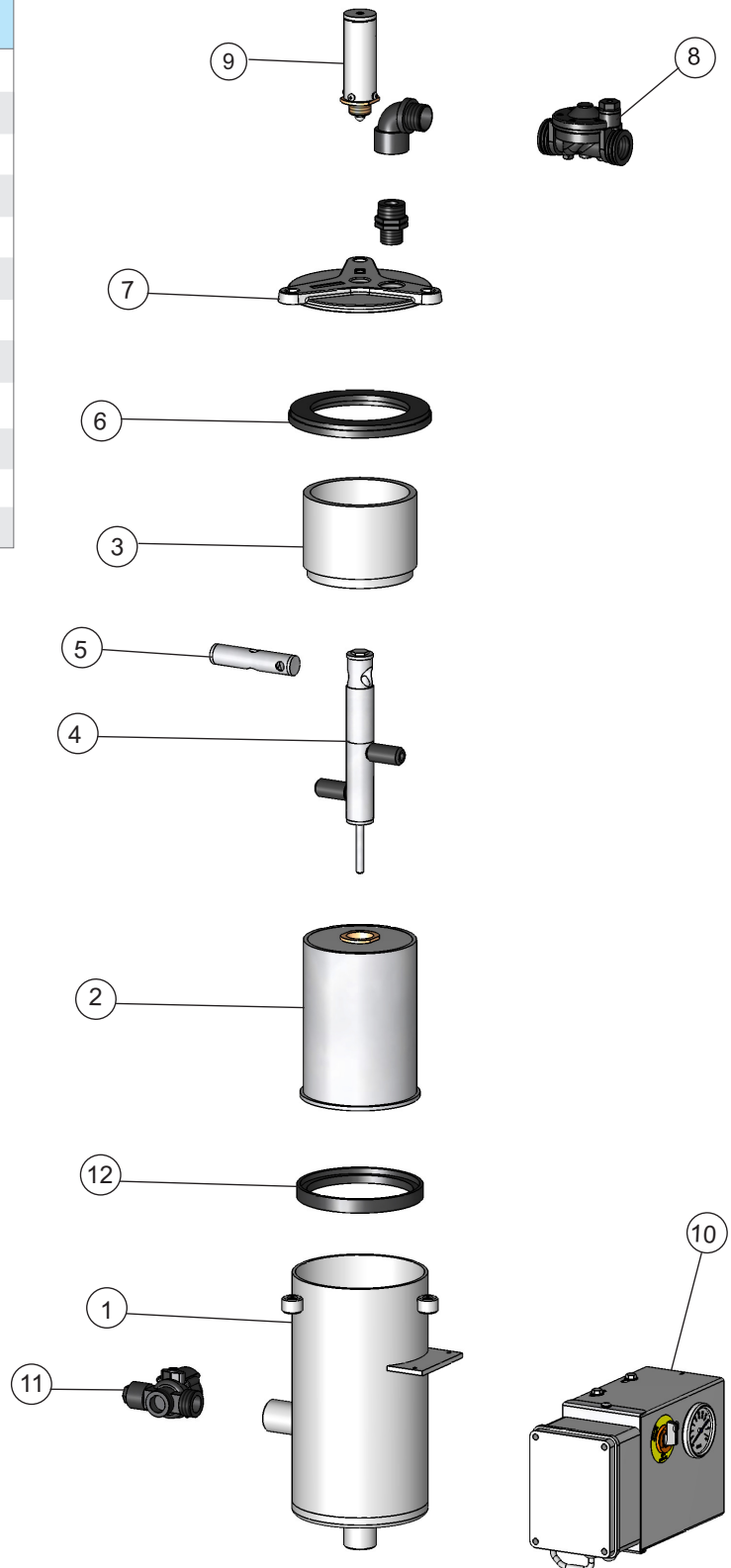

**Models:**  
**85107 (3/4")**  
**85101 (1")**

## GENERAL INSTRUCTIONS

### Operation

- The **Odismatic® Hydraulic** Filter is equipped with an automatic suction system operated by the in line water pressure for cleaning the screen without interfering with the filtration process.
- The cleaning cycle is activated when the differential pressure across the screen reaches 0.5 bar (7.5 psi) with a timer backup.
- The cleaning cycle for models ¾" and 1" takes about 6-8 sec.  
The cleaning cycle for models 1½", 2", 3" and 4" takes about 8 to 12 sec.  
The cleaning cycle for models 851B04L, 6" and 8" takes about 14 to 16 sec.
- The minimum working pressure for models ¾", 1", 1½", 2", 3", 4" is 1 bar (15 psi).  
The minimum working pressure for models 6", 8" is 2 bar (30 psi).  
The maximum working pressure is 10 bar (150 psi).

### WARNING

- **Flushing time should not exceed the recommended time. Longer flushing time might cause damage to the flushing collector bearing inside the filter**

### Installation

- The **Odismatic® Hydraulic Filter** must be installed in vertical position.
- For best results, the filter should be installed as near as possible to the system it is required to protect. However, if low filter inlet pressure is a concern, either before or during flushing, the filter may need to be installed closer to the pressure source.
- Ensure that the upstream pipe size from pressure source to filter is equal to or greater than filter inlet size.
- It is recommended to install inlet and outlet isolation valves for easy maintenance.
- In situations where a constant supply of water is required downstream during filter servicing it is recommended to install Inlet and bypass valves. Note that this also applies in installation of bypass units.
- It is recommended to install a check valve downstream of the filter to prevent reverse flow and to protect the filter from water hammer.
- An Air-Release Valve must be installed on top of the inlet manifold.
- Ensure that the filter is mounted in the proper direction of flow as indicated by the arrows on the filter housing.
- A drain line should be attached to each flushing valve (For details see Technical Manual).
- If pressure is not controlled effectively a pressure relief valve must be inserted before the filtering installation.
- Connect battery to the controller.

## Start-Up

- Slowly open the inlet valve to the filter, allowing the filter to pressurize.
- Disconnect the control tube from the Hydraulic piston and bleed until all of the air is displaced by water. Reconnect the control tube.
- Check for any external leakages and eliminate.
- Slowly open the outlet valve of the filter.
- Initiate a manual flushing, observe the inlet and hydraulic motor chamber pressures. The hydraulic motor chamber pressure should be between 0.8 to 1.5 bar below filter inlet pressure during the flushing cycle.
- Observe the build up of the pressure differential across the filter. It is recommended to observe at least one automatic flushing cycle to ensure that the system is operating properly.

## Manual Flushing

The manual flushing is activated through the flushing control box by depressing the “manual” button.

## Periodic Cleaning

- Initiate a manual flushing cycle and check for proper filter function by observing the pressures as described in Section start-up. This step should be performed for all individual filters in multiple installations.
- Filters equipped with by-pass should be engaged at least once a month. This will clean the valve seat of any accumulated dirt, as well as ensuring proper by-pass operation.

## WARNING

- **Do not tighten or open cover during operation or under pressure.**

## Maintenance

- Each filter is supplied with Technical Manual for detailed maintenance instructions, as well as assembly, installation and operation instructions.
- Any damage to the protective coating of filter must be repaired without delay. Prior to the application of the protective paint, thoroughly clean the damaged spot with the wire brush.

**PACKING / SHIPPING DATA**
**Metric Units**

Model	Inlet / Outlet (inch)	Gross * Weight (kg)	Packaging	Gross Volume (m <sup>3</sup> )
85107	¾"	15	Packed in a carton	0.05
85101	1"	15	Packed in a carton	0.05
851B15	1½"	39	Packed on a pallet	0.17
851B02	2"	40	Packed on a pallet	0.17
851B03	3"	49	Packed on a pallet	0.21
851B04	4"	50	Packed on a pallet	0.21
851B04L	4"	54	Packed on a pallet	0.22
85106	6"	75	Packed on a pallet	0.40
85108	8"	88	Packed on a pallet	0.48

**U.S. Units**

Model	Inlet / Outlet (inch)	Gross * Weight (lbs)	Packaging	Gross Volume (cu.ft)
85107	¾"	33	Packed in a carton	1.77
85101	1"	33	Packed in a carton	1.17
851B15	1½"	86	Packed on a pallet	6.00
851B02	2"	88	Packed on a pallet	6.00
851B03	3"	108	Packed on a pallet	7.50
851B04	4"	110	Packed on a pallet	7.50
851B04L	4"	119	Packed on a pallet	7.70
85106	6"	165	Packed on a pallet	14.00
85108	8"	194	Packed on a pallet	17.00

\* Gross weight includes packaging materials.

**How To Order OdisMatic® Hydraulic**

1. Type of filter required.
2. Catalog Number of filter.
3. Preferred mesh grade.
4. Min. / Max. pressure.
5. Maximal Flow rate.
6. Additional accessories: Nipples/Valves/Pilots/Relays/Manifolds/Pressure Gauges.
7. Other than standard material, required for filter body and cover.
8. Special Coating Requirements.
9. End Connections: Flange (F)  
Victaulic (V)  
Thread (M)