



**Rivulis**  
Irrigation

# Mini Product Guide





## Rivulis Irrigation – Contact Information

<b>Rivulis Headquarters .....</b>	Rivulis Plastro – Israel Gvat MP ha'amakim 3657900 Israel Phone: +972-73-7800-444
<b>Rivulis Australia .....</b>	Rivulis Irrigation PTY 13-15 Duntroon Street Brendale Queensland 4500 Australia Phone: +61-7-3881-4071
<b>Rivulis Europe .....</b>	Rivulis Irrigation, SAS 13 Chemin de Novital Zi la Pointe 31150 Lespinasse, France Phone: +33-(0)5-34-27-05-05
<b>Rivulis USA .....</b>	Rivulis Irrigation 7545 Carroll Road San Diego, CA 92121 Phone: 1-800-685-5557
<b>Rivulis Brazil .....</b>	Rivulis Plastro Irrigação Rua Lineu Anterino Mariano, 255 Distrito Industrial, Uberlandia Minas Gerais (Mg), Brazil Phone: + 55-34-91582106
<b>Rivulis Argentina .....</b>	Rivuis Plastro Bolivar 1365 Norte, Parque Industrial Chimbos San Juan - Argentina Phone:+54 (264) 4319000

# Table of Contents

## Emission Devices

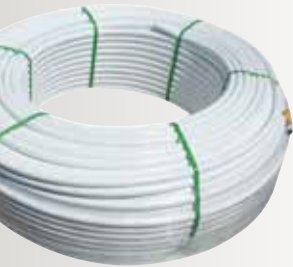

### Drippers

E1000 Dripper .....	6
Katif Flow Regulated Dripper .....	8
Supertif / Supertif ND Flow Regulated Dripper .....	10

### Drip Lines

D2000 Drip Line .....	14
D5000 Flow Regulated Drip Line .....	16
Hydro PC / PC ND Flow Regulated Drip Line .....	20
Hydrogol Drip Line .....	24

### Drip Tapes

Hydrodrip Drip Tape .....	28
Ro-Drip Drip Tape .....	31
T-Tape Drip Tape .....	33

### Jet Spray

Jet+ Jet Stream Spray .....	40
Tornado Ray Jet Stream Spray .....	43

### Sprinklers

Rondo Medium-Range Micro Sprinkler and RFR Flow Regulated Micro Sprinkler .....	46
S2000 Micro Sprinkler .....	50
S5000 Plastic Impact Sprinkler .....	53
Super XL Sprinkler .....	55

### Sprays

FLF Flow Regulated Fog Spray .....	58
Rondo Mist Sprayer .....	60

Source

System Head and Distribution Network



**Strainers**

Rivulis Pre-Filtration Strainer ..... 63

Rivulis Self-Cleaning Suction Strainer ..... 66

**Fertilization**

Rivulis Fertilizer Tank ..... 68

**Filters**

F1000 Hydrocyclone Sand Separator ..... 70

F2000 Media Filter ..... 73

F3100 Metal Screen Filter (Manual) ..... 76

F3200 Metal Screen Filter with Hydraulic Operation ..... 79

F3300 Metal Screen Filter with Electric Operation ..... 82

F3300 Metal Screen Filter with Brushes, Electric Operation (Automatic) .85

F3400 Metal Screen Filter with Continuous Circulation ..... 88

F3400 Metal Screen Filter with Flushing Mechanism ..... 90

F3400 Metal Screen Filter with Internal Flushing Mechanism and Brushes . 92

F6100 Plastic Screen Filter ..... 94

F6400 Plastic Screen Filter ..... 96

F7000 Plastic Disc Filter ..... 98

F9000 Gravity Filter .....100

**Distribution Network**

Pro-Flat Layflat .....102

T-Tape Layflat PVC Hose .....104

**Valves**

Rivulis Air Valves .....107

V1000 Hydraulic Control Valve .....110

V2000 Hydraulic Control Valve .....113

V3000 Hydraulic Control Valve .....115



*Color code indicates flow rate  
Multi-function port*

## E1000 Dripper



### Product Information

Two part construction for easy maintenance  
Multi-function port allowing use of different connectors or micro tubes for numerous applications



### Product Options

Flow rates (1,0 bar): 2,0, 4,0, 8,0 lph  
Bag quantity: 1000



### Operating Guidelines

Operating pressure range: 0,8–2,0 bar  
Installation: Use 2 mm punch tool

**E1000 dripper – Product Specifications/Options**

Nominal Flow Rate (lph)	Color	Flow Rate (@1,0 bar) (lph)	Flow Rate (@1,4 bar) (lph)	Flow Rate (@1,6 bar) (lph)	Item Number
2,0	Brown	2,03	2,39	2,54	201013383
4,0	Black	4,01	4,74	5,06	201013385
8,0	Green	8,02	9,48	10,13	201013386

**E1000 – Maximum Lateral Run Length (m) – Flat Terrain  
Operating pressure: 1,0 bar**

Flow Rate & Cover Color (lph)	Dripper Spacing (cm)	Pipe Diameter (Nominal/Inside Diameter, mm)							
		12/9,8		16/13,6		17,8/15,2		20/17,4	
		7,5%-FV*	10%-FV*	7,5%-FV*	10%-FV*	7,5%-FV*	10%-FV*	7,5%-FV*	10%-FV*
2,0 (Brown)	30	27	30	53	60	68	76	89	101
	50	41	46	79	90	99	112	129	146
	100	70	79	130	147	160	182	206	233
4,0 (Black)	30	17	19	34	38	43	48	57	64
	50	26	29	50	57	63	71	82	93
	100	44	50	83	94	102	116	131	149
8,0 (Green)	30	11	12	21	24	27	31	36	41
	50	16	19	32	36	40	45	53	59
	100	28	31	53	60	65	74	84	95

\* FV – Flow Variation



*Low profile Dripper  
Flow Regulated Dripper*

## Katif Flow Regulated Dripper



### Product Information

Flow regulated

Outstanding flow uniformity over a wide pressure range

Flushes with initial water flow, minimizing clogging risk

Applications: on sloping terrain or where long drip lines are required

Base color: Black



### Operating Guidelines

Operating pressure range: 0,8–3,0 bar

Installation: use 2,8 mm punch tool

Filtration requirements (based on lph/Dripper):

lph/Dripper	Micron	Mesh
All models	130	120

### Product Specifications/Options

Nominal Flow Rate (lph)	Outlet	Operating Pressure Range (bar)
2,3 (Black cover)	Side, Top	0,8–3,0
3,75 (Red cover)	Side, Top	0,8–3,0
8,0 (Green cover)	Side, Top, Side and Top (Dual)	0,8–3,0

**Katif Flow Regulated Dripper – Maximum Lateral Run Length (m) – Flat Terrain**

Nominal Flow Rate	Outlet Color	Hose Size		Pressure	Spacing Between Drippers (cm)					
		ID	OD		33	50	75	100	125	150
(lph)		(mm)	(mm)	(bar)	(m)					
2,3	Black	9,8	12	1,0	23	34	47	61	72	-
				2,0	42	63	89	113	135	-
				3,0	52	76	108	137	165	-
		13,6	16	1,0	49	70	95	117	138	-
				2,0	91	129	178	222	263	-
				3,0	110	156	216	270	320	-
		15,2	17,8	1,0	62	86	117	145	172	-
				2,0	115	162	222	275	324	-
				3,0	138	196	270	336	395	-
		17,4	20	1,0	86	117	158	193	225	-
				2,0	162	223	299	366	428	-
				3,0	197	271	365	448	523	-
3,75	Red	9,8	12	1,0	1,0	25	35	44	52	-
				2,0	2,0	45	64	82	98	-
				3,0	3,0	53	76	97	117	-
		13,6	16	1,0	1,0	50	69	86	102	-
				2,0	2,0	93	129	161	191	-
				3,0	3,0	111	154	192	228	-
		15,2	17,8	1,0	1,0	63	85	106	125	-
				2,0	2,0	117	160	200	236	-
				3,0	3,0	139	192	239	281	-
		17,4	20	1,0	1,0	86	114	140	163	-
				2,0	2,0	162	218	268	312	-
				3,0	3,0	193	260	320	374	-
8,0	Green	9,8	12	1,0	-	15	20	26	31	36
				2,0	-	27	38	48	58	68
				3,0	-	33	47	59	71	83
		13,6	16	1,0	-	30	41	51	60	69
				2,0	-	57	78	97	114	131
				3,0	-	70	97	120	141	162
		15,2	17,8	1,0	-	38	52	64	75	86
				2,0	-	72	98	121	143	162
				3,0	-	89	122	150	176	201
		17,4	20	1,0	-	51	68	83	96	110
				2,0	-	95	128	157	184	209
				3,0	-	118	159	195	229	260



Color code indicates  
flow rate

## Supertif / Supertif ND Flow Regulated Dripper



### Product Information

Flow regulated  
 Outstanding resistance to clogging  
 Self-flushing mechanism  
 Base color for each type of dripper  
 Supertif: Black  
 Supertif ND / NDH: Brown  
 Supertif ND MOP: Light Blue  
 Supertif NDH MOP: Blue



### Product Options

Outlet types: barb, side-outlet barb, and conic  
 Bag quantity: 1000



### Operating Guidelines

Operating pressure range:  
 Supertif: 0,6–3,5 (25 lph: 1,25–3,5) bar  
 Supertif ND (No-Drain): 0,7–3,5 bar  
 Supertif NDH (No-Drain High): 1,2–3,5 bar  
 Supertif ND MOP: 1,3–3,5 bar  
 Supertif NDH MOP: 1,3–3,5 bar  
 (see specifications on the next page)  
 Installation: Use 2 mm punch tool

### Filtration requirements (based on lph/Dripper):

lph/Dripper	Micron	Mesh
≤1,6	100	150
>1,6	130	120

**Supertif – Product Specifications/Options**

Product	Nominal Flow Rates (lph)	Outlet	Operating Pressure Ranges (bar)	Start Opening Pressure (bar)	Sealing Pressure (bar)
Supertif	2,2, 3,85, 7,8, 12,0, 25,0	Conic, barb*	0,6–3,5 (25 lph: 1,25–3,5)	–	–
Supertif ND	1,1, 2,2, 3,85, 7,8	Conic, barb,* side outlet barb*	0,7–3,5	–	0,15
Supertif NDH	1,6, 3,1, 8,0, 11,0	Conic, barb,** side outlet barb***	1,2–3,5	–	0,35
Supertif ND MOP	1,1, 2,2, 3,85	Side outlet barb	1,3–3,5	0,70	0,20
Supertif NDH MOP	1,6, 3,1, 5,3, 8,0	Conic, side outlet***	1,3–3,5	0,70	0,20

\* For barb 2,2 lph only

\*\* For barb 3,1 lph only

\*\*\* For side outlet barb 1,6 and 3,1 lph only

**Supertif Flow Regulated Dripper – Maximum Lateral Run Length (m) – 90% Emission Uniformity, Flat Terrain**

Product	Nominal Flow Rate (lph)	Outlet Color*	Hose Size		Spacing Between Drippers (cm)					
			ID (mm)	OD (mm)	30	50	60	75	100	150
Supertif	2,2	Brown	9,8	12	51	79	91	108	135	183
			13,6	16	102	152	174	206	253	336
			15,2	17,8	129	191	217	255	312	411
			17,4	20	172	249	283	331	402	527
Supertif	3,85	Black	9,8	12	35	55	63	75	94	128
			13,6	16	71	106	121	143	176	234
			15,2	17,8	90	133	152	178	218	288
			17,4	20	120	174	198	231	281	369
Supertif	8,0	Green	9,8	12	22	35	40	48	60	81
			13,6	16	45	67	77	91	112	149
			15,2	17,8	57	84	96	113	139	183
			17,4	20	76	111	126	147	179	236
Supertif	12,0	Red	9,8	12	17	26	30	36	45	62
			13,6	16	34	51	58	69	85	113
			15,2	17,8	43	64	73	86	105	140
			17,4	20	58	84	95	112	136	179
Supertif	25,0	Orange	9,8	12	8	13	14	17	22	29
			13,6	16	16	25	28	33	40	54
			15,2	17,8	20	31	35	41	50	66
			17,4	20	28	41	46	53	65	86

Inlet Pressure 2,0 bar

\* Base color: Black

### Supertif ND Flow Regulated Dripper – Maximum Lateral Run Length (m) – 90% Emission Uniformity, Flat Terrain

Product	Nominal Flow Rate	Outlet Color*	Hose Size		Spacing Between Drippers (cm)					
			ID	OD	30	50	60	75	100	150
	(lph)		(mm)	(mm)	(m)					
Supertif ND	1,1	Grey	9,8	12	71	111	128	153	190	257
			13,6	16	143	214	245	289	355	470
			15,2	17,8	182	267	305	359	438	578
			17,4	20	242	350	398	464	564	738
Supertif ND	2,2	Brown	9,8	12	45	71	81	98	122	164
			13,6	16	91	137	157	185	227	303
			15,2	17,8	116	171	196	230	281	371
			17,4	20	155	224	255	298	362	474
Supertif ND	3,85	Black	9,8	12	32	49	56	68	85	116
			13,6	16	63	95	109	129	159	212
			15,2	17,8	81	119	136	160	196	260
			17,4	20	108	157	178	208	253	332
Supertif ND	7,8	Green	9,8	12	20	31	36	43	53	72
			13,6	16	40	60	69	82	101	135
			15,2	17,8	51	76	86	102	125	165
			17,4	20	68	100	113	133	161	212

Inlet Pressure 2,0 bar

\* Base color: Brown

### Supertif NDH Flow Regulated Dripper – Maximum Lateral Run Length (m) – 90% Emission Uniformity, Flat Terrain

Product	Nominal Flow Rate	Outlet Color*	Hose Size		Spacing Between Drippers (cm)					
			ID	OD	30	50	60	75	100	150
	(lph)		(mm)	(mm)	(m)					
Supertif NDH	1,6	Dark Grey	9,8	12	47	72	83	99	123	167
			13,6	16	93	139	160	188	231	306
			15,2	17,8	118	174	199	233	285	375
			17,4	20	157	228	259	302	367	482
Supertif NDH	3,1	Blue	9,8	12	30	47	55	65	81	110
			13,6	16	61	91	104	123	151	201
			15,2	17,8	77	114	130	152	187	246
			17,4	20	103	149	169	197	240	317
Supertif NDH	8,0	Green	9,8	12	16	26	29	35	44	59
			13,6	16	32	49	56	67	82	110
			15,2	17,8	42	61	70	83	101	134
			17,4	20	56	81	92	108	131	173
Supertif NDH	11,0	Red	9,8	12	13	21	24	29	35	48
			13,6	16	27	40	46	55	67	89
			15,2	17,8	34	50	57	68	83	110
			17,4	20	45	66	76	88	106	141

Inlet Pressure 2,0 bar

\* Base color: Brown

### Supertif ND MOP Flow Regulated Dripper – Maximum Lateral Run Length (m) – 90% Emission Uniformity, Flat Terrain

Product	Nominal Flow Rate	Outlet Color*	Hose Size		Spacing Between Drippers (cm)					
			ID	OD	30	50	60	75	100	150
		(lph)	(mm)	(mm)	(m)					
Supertif ND MOP	1,1	Grey	9,8	12	56	87	101	120	149	201
			13,6	16	113	168	193	227	279	369
			15,2	17,8	143	210	240	281	343	453
			17,4	20	190	275	312	364	442	579
Supertif ND MOP	2,2	Brown	9,8	12	36	56	64	77	96	129
			13,6	16	72	108	123	145	178	237
			15,2	17,8	91	134	154	180	220	291
			17,4	20	122	176	200	233	284	371
Supertif ND MOP	3,85	Black	9,8	12	25	38	45	53	67	90
			13,6	16	50	75	86	101	125	167
			15,2	17,8	64	94	107	125	154	203
			17,4	20	85	123	140	163	198	260

Inlet Pressure 2,0 bar

\* Base color: Light Blue

### Supertif NDH MOP Flow Regulated Dripper – Maximum Lateral Run Length (m) – 90% Emission Uniformity, Flat Terrain

Product	Nominal Flow Rate	Outlet Color*	Hose Size		Spacing Between Drippers (cm)					
			ID	OD	30	50	60	75	100	150
		(lph)	(mm)	(mm)	(m)					
Supertif NDH MOP	1,6	Dark Grey	9,8	12	44	68	79	94	117	159
			13,6	16	88	132	151	179	219	291
			15,2	17,8	112	165	188	221	270	356
			17,4	20	149	216	245	286	348	456
Supertif NDH MOP	3,1	Blue	9,8	12	29	44	52	62	77	104
			13,6	16	58	86	98	117	143	191
			15,2	17,8	73	108	123	145	177	234
			17,4	20	97	141	160	188	227	300
Supertif NDH MOP	5,3	Violet	9,8	12	20	31	36	44	54	74
			13,6	16	41	61	70	83	101	135
			15,2	17,8	51	77	88	103	125	167
			17,4	20	69	100	113	134	161	212
Supertif NDH MOP	8,0	Light Green	9,8	12	15	24	28	33	42	56
			13,6	16	31	47	53	63	78	104
			15,2	17,8	40	58	67	79	96	128
			17,4	20	53	77	88	102	124	164

Inlet Pressure 2,0 bar

\* Base color: Blue



*Large surface inlet filter  
Large cross sectional  
labyrinth*

## D2000 Drip Line

The D2000 Drip Line delivers the right combination of features to produce both reliable and efficient performance in a mid and heavy wall thickness drip line. The innovative flat dripper design minimizes resistance to the water flow in the main channel, allowing growers to utilize longer lateral runs than similar round dripper drip lines. The design of the dripper incorporates features such as large filtration area, large dripper channel, and sharp teeth to create a turbulent flow which resists clogging.



### Product Information

Nominal diameter: 16 and 20 mm

Wall thickness:

For 16 mm – 30, 35, 40 and 45 mil

For 20 mm – 40 mil

Flow rates: 1,0, 2,0 and 4,0 lph

Standard Dripper spacings: 20\*, 25\*, 30, 40, 50, 60, 75, 100 cm

\*only for 2,0 lph



### Operating Guidelines

Recommended operating pressure: 1 bar

### Filtration requirements (based on lph/Dripper):

lph/Dripper	Micron	Mesh
≤ 1,00	100	150
> 1,00	130	120

**D2000 Drip Line – Product Specifications/Options**

Product	Inside Diameter	Wall Thickness	Wall Thickness	Flow Rate	Maximum Operating Pressure	Reel Length
(mm)	(mm)	(mil)	(mm)	(lph)	(bar)	(m)
16	13,8	30	0,76	1,00	2,50	600
				2,00		
				4,00		
		35	0,89	3,00	500	1,00
						2,00
						4,00
		40	1,02	3,00	400	1,00
						1,95
						3,95
		45	1,14	3,00	400	1,00
						1,95
						3,95
20	17,6	40	1,02	1,00	3,00	400

**D2000 – Maximum Recommended Drip Line Length (m) on Flat Terrain**

Product (mm / mil / lph)	Max Flow Rate Difference: 7,5% Spacing Between Drippers (Cm)							Max Flow Rate Difference: 10% Spacing Between Drippers (Cm)						
	20	30	40	50	60	75	100	20	30	40	50	60	75	100
16/35/1	69	92	112	130	147	170	206	79	105	128	150	169	196	236
16/35/2	45	60	74	86	97	112	135	52	69	84	98	111	128	155
16/35/4	29	38	47	55	62	72	87	33	44	54	63	71	83	100
16/40/1	70	94	114	133	150	174	210	81	106	131	152	172	200	242
16/40/2	46	61	74	87	98	113	137	52	70	85	100	112	131	157
16/40/4	29	39	48	56	62	73	88	33	45	54	64	72	83	101



*Multiple inlet filters  
and large cross section  
labyrinth for High  
resistance to clogging  
Accurate flow regulating  
membrane*

## D5000 Flow Regulated Drip Line



### Product Information

Flow regulated drip line  
Multiple filter inlets  
Large cross section labyrinth  
Self-closing slit outlet on 15 mil product  
Outlet:  
15 mil wall thickness – Slit  
Above 15 mil – Hole



### Product Options

Diameters: 16, 17, 20, 22, 23 mm  
Wall thickness: 15–47 mil  
Flow rates: 0,65, 1,0, 1,5, 2,0 lph



### Operating Guidelines

Operating pressure range: 0,5–3,5 bar, according to wall thickness

### Filtration Requirements (based on lph/Dripper):

lph/Dripper	Micron	Mesh
≤1,0	100	150
>1,0	130	120

**D5000 Flow Regulated Drip Line – Product Specifications/Options**

Nominal Diameter	ID	OD	Wall Thickness		Maximum Operating pressure	Roll Length	Roll Weight	Rolls per Pallet
(mm)	(mm)	(mm)	(mil)	(mm)	(bar)	(m)	(kg)	
16	16,4	17,16	15	0,38	2,2	800	17,7	16
	13,8	15,32	30	0,76	2,5	600	21,2	20
	13,8	15,58	35	0,89	3,0	500	21,0	20
	13,8	15,83	40	1,02	3,5	400	20,0	20
17	15,3	16,20	18	0,45	2,2	1100	27,5	20
	15,3	16,57	25	0,63	2,5	800	27,5	20
	15,3	17,08	35	0,89	3,0	450	20,5	20
	15,3	17,33	40	1,02	3,5	450	23,0	20
	15,3	17,59	45	1,14	3,5	400	24,0	20
20	17,6	19,63	40	1,02	3,5	350	20,0	20
	17,6	19,89	45	1,14	3,5	300	20,8	20
	17,6	19,99	47	1,19	3,5	300	23,0	20
22	22,2	22,96	15	0,38	1,8	800	22,2	20
	22,2	23,47	25	0,63	2,5	500	25,0	20
23	20,8	22,84	40	1,02	3,0	350	23,5	12

Standard Dripper Spacings: 15, 20, 30, 40, 50, 60, 75, 100 cm

**D5000 Flow Regulated Drip Line – Maximum Lateral Run Length (m), Flat Terrain**

Nominal Diameter	Wall Thickness	Flow Rate*	Spacing Between Drippers (cm)							
			15	20	30	40	50	60	75	100
(mm)	(mil)	(lph)	(m)							
16	15	0,65	174	223	312	392	467	536	632	777
		1,0	131	168	236	297	353	406	479	590
		1,5	101	129	181	228	272	312	369	454
		2,0	83	107	150	190	226	259	306	377
	30	0,65	133	172	243	308	369	425	503	624
		1,0	101	130	184	234	280	322	383	474
		1,5	77	100	141	179	215	248	294	365
		2,0	64	82	117	149	178	206	245	303
	35	0,65	144	186	263	333	399	460	545	676
		1,0	109	140	199	252	302	349	414	513
		1,5	83	107	152	194	232	268	318	395
		2,0	69	89	126	161	193	223	264	328
	40	0,65	153	198	280	355	425	490	581	721
		1,0	116	149	212	269	322	371	441	547
		1,5	89	114	163	206	248	286	340	421
		2,0	73	95	135	171	205	237	282	350

\* Calculated at maximum operating pressure

### D5000 Flow Regulated Drip Line – Maximum Lateral Run Length (m), Flat Terrain

Nominal Diameter	Wall Thickness	Flow Rate*	Spacing Between Drippers (cm)							
			15	20	30	40	50	60	75	100
(mm)	(mil)	(lph)	(m)							
17	18	0,65	162	207	290	364	433	496	585	720
		1,0	122	157	219	276	328	377	445	547
		1,5	94	120	169	212	253	290	342	422
		2,0	77	99	140	176	210	241	284	350
	25	0,65	171	219	306	386	459	526	620	763
		1,0	128	164	230	290	345	396	467	576
		1,5	98	126	177	223	266	305	360	444
		2,0	81	104	147	185	221	253	299	368
	35	0,65	185	237	331	417	496	569	671	826
		1,0	139	179	251	316	376	432	510	628
		1,5	107	137	193	243	289	332	393	484
		2,0	88	114	160	202	240	276	326	402
	40	0,65	197	252	353	445	529	607	717	882
		1,0	148	190	267	337	401	461	544	670
		1,5	114	146	205	259	309	355	419	516
		2,0	94	120	169	213	255	293	346	426
	45	0,65	197	252	353	445	529	607	717	882
		1,0	148	190	267	337	401	461	544	670
		1,5	114	146	205	259	309	355	419	516
		2,0	94	120	169	213	255	293	346	426
20	40	0,65	266	339	470	588	695	795	935	1145
		1,0	201	256	356	446	528	604	710	870
		1,5	154	197	274	343	406	465	547	671
		2,0	128	163	227	284	337	386	455	558
	45	0,65	266	339	470	588	695	795	935	1145
		1,0	201	256	356	446	528	604	710	870
		1,5	154	197	274	343	406	465	547	671
		2,0	128	163	227	284	337	386	455	558

\* Calculated at maximum operating pressure

### D5000 Flow Regulated Drip Line – Maximum Lateral Run Length (m), Flat Terrain

Nominal Diameter	Wall Thickness	Flow Rate*	Spacing Between Drippers (cm)							
			15	20	30	40	50	60	75	100
(mm)	(mil)	(lph)	(m)							
20	47	0,65	266	339	470	588	695	795	935	1145
		1,0	201	256	356	446	528	604	710	870
		1,5	154	197	274	343	406	465	547	671
		2,0	128	163	227	284	337	386	455	558
22	15	0,65	332	415	562	692	810	919	1070	1299
		1,0	253	316	428	527	617	700	816	990
		1,5	194	243	330	406	476	540	629	764
		2,0	161	202	274	338	396	449	524	636
	25	0,65	386	483	656	808	946	1073	1250	1519
		1,0	290	364	494	609	714	810	944	1147
		1,5	223	280	380	469	550	625	728	886
		2,0	185	232	316	390	457	520	606	737
23	40	0,65	362	456	623	770	904	1028	1201	1461
		1,0	273	344	470	582	683	778	908	1106
		1,5	209	264	362	448	527	599	701	853
		2,0	174	219	300	372	438	499	582	710

\* Calculated at maximum operating pressure



Dual outlets in each  
Dripper  
Large Dripper Channel

## Hydro PC / PC ND Flow Regulated Drip Line



### Product Information

Highly resistant to clogging due to the large cross section labyrinth and the continuous flushing of the inlet filter by the water flow

Pressure difference in the regulating chamber creates a continuous self-flushing operation

Flow Regulated

No-Drain (ND) features prevents Drip line from ingesting containments during pressure drop with system Shut-down. Great for applications such as Sub-surface drip systems and pulse irrigation in greenhouses and fields



### Product Options

Diameters: 12, 16, 17, 20 mm

Wall thickness: 35-47 mil

Hydro PC Flow rates: 1,05 (12 mm), 1,2, 1,6, 2,2, 3,6 lph

Hydro PC ND Flow rates: 1,05 (12 mm), 1,35, 1,75\*, 2,35, 3,75\*\* lph

Hose Color: Black or white



### Operating Guidelines

Operating pressure range: 0,8-3,5 bar, (For 35 mil, maximum pressure: 3,0 bar)

Sealing pressure (ND): 0,1 bar

### Filtration Requirements (based on lph/Dripper):

lph/Dripper	Micron	Mesh
≤1,2	100	150
>1,2	130	120

\* Hydro PC ND 17 mm flow rate – 1,6 lph

\*\* Hydro PC ND 20 mm flow rate – 3,6 lph

**Hydro PC Flow Regulated Drip Line – Product Specifications/Options**

Product	Nominal Diameter	ID	Wall Thickness	Flow Rate	Max Pressure	Roll Length
	(mm)	(mm)	(mil)	(lph)	(bar)	(m)
Hydro PC	12	10,4	25, 35, 40	1,05	2,5, 3,0, 3,5	600
Hydro PC	16	13,8	35, 40, 45	1,2	3,0, 3,5, 3,5	400
		13,8	35, 40, 45	1,6	3,0, 3,5, 3,5	400
		13,8	35, 40, 45	2,2	3,0, 3,5, 3,5	400
		13,8	35, 40, 45	3,6	3,0, 3,5, 3,5	400
Hydro PC	17	15,3	35, 40, 45, 47	1,2	3,0, 3,5, 3,5, 3,5	350
		15,3	35, 40, 45, 47	1,6	3,0, 3,5, 3,5, 3,5	350
		15,3	35, 40, 45, 47	2,2	3,0, 3,5, 3,5, 3,5	350
		15,3	35, 40, 45, 47	3,6	3,0, 3,5, 3,5, 3,5	350
Hydro PC	20	17,6	35, 40, 45, 47	1,2	3,0, 3,5, 3,5, 3,5	300
		17,6	35, 40, 45, 47	1,6	3,0, 3,5, 3,5, 3,5	300
		17,6	35, 40, 45, 47	2,2	3,0, 3,5, 3,5, 3,5	300
		17,6	35, 40, 45, 47	3,6	3,0, 3,5, 3,5, 3,5	300

Standard Dripper Spacings: 15, 20, 30, 40, 50, 60, 75, 100 (cm)

**Hydro PC ND Flow Regulated Drip Line – Product Specifications/Options**

Product	Nominal Diameter	ID	Wall Thickness	Flow Rate	Max Pressure	Roll Length
	(mm)	(mm)	(mil)	(lph)	(bar)	(m)
Hydro PC ND	12	10,4	35, 40	1,05	3,0, 3,5	600
	16	13,8	35, 40, 45	1,35, 1,75, 2,35, 3,75	3,0, 3,5, 3,5	400
	17	15,3	40, 45, 47	1,35, 1,75, 2,35, 3,75	3,5	350
	20	17,6	45, 47	1,35, 1,75, 2,35, 3,75	3,5	300

### Hydro PC Flow Regulated Drip Line – Maximum Lateral Run Length (m), Flat Terrain

Product	Nominal Diameter	ID	Wall Thickness	Nominal Flow Rate	Inlet Pressure	Spacing Between Drippers (cm)							
						15	20	30	40	50	60	75	100
	(mm)	(mm)	(mil)	(lph)	(bar)	(m)							
Hydro PC	12	10,4	35	1,05	1,0	28	36	52	65	78	90	107	132
					2,0	49	63	90	114	137	158	189	234
					3,0	55	70	101	129	154	178	212	264
Hydro PC	16	13,8	40 45	1,60	1,0	-	46	65	82	99	113	131	166
					2,0	-	80	114	144	173	200	233	294
					3,0	-	98	139	177	213	245	288	363
				2,20	1,0	-	37	53	67	80	92	108	135
					2,0	-	65	92	117	141	163	192	240
					3,0	-	79	113	144	173	200	236	295
				3,60	1,0	-	27	38	49	58	67	79	98
					2,0	-	47	67	85	102	118	140	174
					3,0	-	57	82	104	126	145	172	215
Hydro PC	20	17,6	45	1,60	1,0	-	75	105	132	157	179	206	259
					2,0	-	131	184	232	276	317	369	461
					3,0	-	161	226	285	340	391	456	569
				2,20	1,0	-	61	85	107	128	146	167	211
					2,0	-	107	150	189	225	258	300	376
					3,0	-	131	184	232	276	318	457	463
				3,60	1,0	-	44	62	78	93	106	122	154
					2,0	-	77	109	137	163	188	219	274
					3,0	-	95	133	168	201	231	270	337

### Hydro PC ND Flow Regulated Drip Line – Maximum Lateral Run Length (m), Flat Terrain

Product	Nominal Diameter	ID	Wall Thickness	Nominal Flow Rate	Inlet Pressure	Spacing Between Drippers (cm)							
						15	20	30	40	50	60	75	100
	(mm)	(mm)	(mil)	(lph)	(bar)	(m)							
Hydro PC ND	12	10,4	35 40	1,05	1,0	28	36	52	65	78	90	107	132
					2,0	49	63	90	114	137	158	189	234
					3,0	55	77	110	140	169	195	232	289
Hydro PC ND	16	13,8	40 45	1,75	1,0	-	43	62	78	93	107	176	157
					2,0	-	76	107	136	163	188	275	278
					3,0	-	92	131	167	201	232	332	342
				2,35	1,0	-	36	51	64	77	88	125	130
					2,0	-	62	89	112	135	156	223	230
					3,0	-	76	108	138	166	191	274	283
				3,75	1,0	-	26	37	47	57	65	93	96
					2,0	-	46	65	83	100	115	167	170
					3,0	-	56	80	102	122	142	205	209
Hydro PC ND	17	15,3	40	1,35	1,0	-	75	105	133	158	181	214	264
					2,0	-	116	163	206	246	283	335	412
					3,0	-	139	197	248	297	341	407	499
				3,75	1,0	-	30	43	54	64	73	93	107
					2,0	-	56	79	100	120	138	181	202
					3,0	-	69	98	124	149	171	205	251
Hydro PC ND	20	17,6	45	1,75	1,0	-	71	99	124	148	169	197	245
					2,0	-	124	174	219	261	299	351	435
					3,0	-	152	213	269	321	368	433	537
				2,35	1,0	-	54	76	95	113	129	163	187
					2,0	-	101	141	178	212	244	290	355
					3,0	-	124	175	220	263	302	358	440
				3,60	1,0	-	44	62	78	93	106	124	154
					2,0	-	77	109	137	163	188	221	274
					3,0	-	95	133	168	201	231	272	337

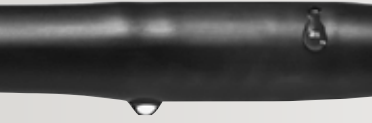

*High quality resins for durable, multi-season application.*

*Two water outlets in each Dripper*

## Hydrogol Drip Line



### Product Information

Designed with a large cross-sectional labyrinth - provides a turbulent water flow which minimizes the formation of residues that may cause clogging. Manufactured with two outlets and two inlet filters which ensure high resistance to clogging and reliable long life performance.

High clogging resistance due to the large channel and large inlet filter



### Product Options

Diameters: 12, 16, 20 mm

Wall thickness: 25-45 mil

Flow rates at 1,0 bar: 1,0-8,0 lph

(Flow rates vary according to wall thickness and inlet pressure)

Hose color: Black or White



### Operating Guidelines

Standard operating pressure: 1,0 bar

Operating pressure range: 0,8-2,0 bar

### Filtration Requirements (based on lph/Dripper):

lph/Dripper	Micron	Mesh
≤1,2	100	150
>1,2	130	120

**Hydrogol Drip Line – Product Specifications/Options**

Nominal Diameter	ID	Wall thickness	Nominal Flow Rate (@1,0 bar)	Roll Length	Roll Weight
(mm)	(mm)	(mil)	(lph)	(m)	(kg)
12	10,4	35	1,0, 2,0	600	21
		40	1,0, 2,0	600	21
16	13,8	35	1,0, 1,6, 2,0, 4,0, 8,0	400	22
		40	1,0, 1,6, 2,0, 4,0, 8,0	400	22
20	17,6	40	1,2, 2,0, 4,0	300	22
		45	1,2, 2,0, 4,0	300	22

Standard Dripper Spacings: 15, 20, 30, 40, 50, 60, 75, 100 (cm)

**Hydrogol Drip Line – Maximum Lateral Run Length (m), Flat Terrain**

Nominal Diameter	ID	Wall Thickness	Flow Rate*	Spacing Between Drippers (cm)				
				20	30	50	75	100
(mm)	(mm)	(mil)	(lph)	(m)				
12	10,4	35	1,0	58	80	119	161	196
			2,0	33	47	70	94	115
16	13,8	35	1,6	65	90	132	176	215
			2,0	56	77	114	152	186
			4,0	37	52	76	102	125
		40	1,0	95	131	192	257	313
			1,6	70	96	142	189	231
			2,0	59	82	120	161	196
20	17,6	40	4,0	39	54	80	107	130
			1,2	134	184	267	354	430
			2,0	88	121	176	233	284
		45	4,0	61	84	123	163	199
			1,2	137	187	272	361	439
			2,0	92	125	183	242	295
			4,0	62	84	123	164	199





For length of run technical data, see the Hydrogol Drip line Performance Specifications sheet.

\* At 1,0 bar pressure









\*\* Pressure at drip line inlet: 1,2 bar



### Drip Line Fittings – Start Connectors

Image	Description	Item Number
	Barbed start connector black 12 mm – multi barb	101001883
	Barbed start connector green 16S – 16 mm – multi barb	101001885
	Barbed start connector green 17 mm – multi barb	101003837
	Barbed start connector black 20 mm – multi barb	101001884
	Start connector grommet for PVC and PE pipes	101001886

### Drip Line Fittings – Couplings, Reducing Couplings

Image	Description	Item Number
	Barbed coupling black 12x12 – multi barb	101001887
	Barbed coupling green 16x16S – multi barb	101001889
	Barbed coupling green 17x17 – multi barb	101001965
	Barbed coupling black 20x20 – multi barb	101001888
	Barbed reducing coupling green 16x12 – multi barb	101003908
	Barbed reducing coupling green 17x16 – multi barb	101001970
	Barbed reducing coupling green 20x16 – multi barb	101003888
	Barbed reducing coupling green 20x17 – multi barb	101003895



### Drip Line Fittings – 8 mm Fittings

Image	Description	Item Number
	8 mm insert coupling – green	101003880
	8 mm insert coupling – brown	101030574
	8 mm insert elbow – green	101003938
	8 mm insert elbow – brown	101030604
	8 mm insert tee – green	101003973
	8 mm insert tee – brown	101030610
	8 mm x 3/8" THM adaptor – green	101030601
	8 mm x 3/8" THM adapter – brown	101030602
	8 mm x 1/2" THM adapter – green	101003925
	8 mm x 1/2" THM adapter – brown	101030600

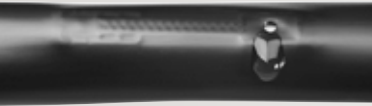

*Precision-molded flat dripper*

*Turbulent flow path*

## Hydrodrip Drip Tape

Hydrodrip Drip Tape is an economical solution for annual row crops, field crops, and greenhouses. Engineered with an efficient turbulent flow path, the Hydrodrip's labyrinth design minimizes clogging.

Hydrodrip Drip Tape is a good choice for manual or mechanized layout and retrieval. It is available in a wide range of diameters and wall thicknesses. And with its flap outlet, Hydrodrip Drip Tape reduces the ingestion of soil on system shut-down when used in a subsurface application.



### Product Information

Drip tape with drippers welded to the inner tube wall.  
Efficient and turbulent flow path minimizes clogging



### Product Options

Diameters: 16, 22, 25 mm

Wall thickness: 10–25 mil

Standard Dripper spacings: 20, 30, 40, 50, 60 cm  
(Optional: 15 cm)

Flow rates for drip lines with wall thickness 15 mil:  
0,8, 1,2, 1,6, 2,1 lph (Flow rates vary according to wall thickness and inlet pressure)

Rolls per pallet: 16 or 20 (see price book for details)



### Operating Guidelines

Standard operating pressure: 1,0 bar

Maximum pressure: according to wall thickness

### Filtration Requirements (based on lph/Dripper):

lph/Dripper	Micron	Mesh
0,8–1,2	100	150
>1,2	130	120

**Hydrodrip Drip Tape – Product Specifications/Options**

Product	Diameter (ID)	Wall Thickness	Maximum Operating Pressure	Roll Length
	(mm)	(mil)	(bar)	(m)
Hydrodrip	16 (16,4)	10	1,3	2200
Hydrodrip	16 (16,4)	12	1,8	1600
Hydrodrip	16 (16,4)	15	2,2	1300
Hydrodrip	16 (15,2)	18	2,2	1500
Hydrodrip	16 (15,2)	25	2,5	800
Hydrodrip	22 (22,2)	10	1,0	1500
Hydrodrip	22 (22,2)	12	1,4	1200
Hydrodrip	22 (22,2)	15	1,8	1000
Hydrodrip	22 (22,2)	25	2,5	700

\* Flow rates indicated are for drip lines with 15 mil wall thickness

\*\* Pressure at drip line inlet: 1,2 bar

### Hydrodrip – Maximum Drip Tape Run (m) on Flat Terrain – Flow Variation: EU 90%

Flow Rate	Diameter/ Wall Thickness	Inside Diameter	Spacing Between Emitters (cm)				
(lph)	(mm/mil)	(mm)	20	30	33	40	50
0,8	16/10-16/15	16,4	168	225	241	275	321
	16/18	15,2	154	207	221	252	294
	22/10 - 22/18	22,2	135	181	193	221	258
1,2	16/10-16/15	16,4	135	181	193	221	258
	16/18	15,2	123	164	176	201	234
	16/25	15,2	117	156	167	191	223
	22/10	22,2	238	316	338	385	448
	22/15	22,2	240	319	341	389	452
1,65	16/10-16/15	16,4	113	151	162	185	216
	16/18	15,2	99	132	142	162	189
	16/25	15,2	98	132	141	161	188
	22/10	22,2	199	265	283	322	375
	22/15	22,2	201	268	286	326	379
2,1	16/10-16/15	16,4	84	112	120	137	160
	16/18	15,2	84	112	120	137	160
	16/25	15,2	83	111	119	136	158
	22/10	22,2	153	208	223	256	300
	22/15	22,2	166	221	237	270	314



*Turbulent Flow Channel  
Dual Inlets*

## Ro-Drip Drip Tape

Ro-Drip Drip Tape provides a reliable, cost-effective solution for many subsurface and above ground drip irrigation applications. Ro-Drip Drip Tape is specifically engineered to deliver uniform flow rates while addressing the most difficult maintenance issue faced by drip growers today: blockage during high contaminant conditions.



### Product Information

Vortex flow action/ turbulent flow channel  
Expanding flow channel  
Precision-molded channel



### Product Options

Diameters: 16, 22 mm  
Wall thickness: 5–10 mil  
Dripper spacings: 10–40 cm  
Flow rates at 0,55 bar: 185–750 lph/ 100 m  
Rolls per pallet: 16



### Operating Guidelines

Standard operating pressure: 0,55 bar  
Maximum pressure: according to wall thickness

### Filtration Requirements (based on lph/Dripper):

lph/Dripper	Micron	Mesh
0,65–1,2	100	150
>1,2	130	120

**Ro-Drip Drip Tape – Product Specifications/Options\***

Diameter	Wall Thickness	Dripper Spacings	Flow Rates (@0,55 bar)	Flushing Pressure	Roll Length	Roll Weight
(mm)	(mil)	(cm)	(lph / 100m)	(bar)	(m)	(kg)
16	5	10, 20, 30	185, 250, 300, 340, 500	0,83	3810	33
	6	10, 20, 30	250, 300, 340, 500, 750	1,04	3048	32
	8	10, 20,30, 40	185,250,300,340,500,750	1,04	2286	30
	10	30	300	1,38	1828	31
22	8	20, 30	185, 300, 500	1,04	1737	29
	10	30	185	1,38	1524	33

\* Not all configuration available. See price book for available configurations.

**Ro-Drip – Maximum Lateral Run Length (m)**

Diameter	Drip Outlet Spacing	Flow Rate	Emission Uniformity	0% Slope
(mm)	(cm)	(lph / 100m)	Pressure (0,55 bar)	(m)
16	10	500	90%	167
	10	750	90%	97
	20	250	90%	191
	20	340	90%	162
	20	500	90%	126
	30	185	90%	230
	30	300	90%	175
22	20	500	90%	209
	30	185	90%	370
	30	300	90%	286

For more length of run technical data, see the Ro-Drip Performance Specifications sheet.

**Ro-Drip Drip Tape – flow Rate (lph), Vs. Pressure\***

Diameter	Nominal Flow Rate	Flow Rate						
		@ 0,4 bar	@ 0,44 bar	@ 0,49 bar	@ 0,55 bar	@ 0,59 bar	@ 0,64 bar	@ 0,69 bar
(mm)	(lph / 100m)	(m)						
16	185	154	165	175	187	194	203	212
	250	205	219	233	248	258	270	282
	300	250	266	281	298	309	322	335
	340	277	296	314	335	349	365	381
	500	410	439	466	497	517	541	564
	750	625	665	702	745	772	805	837
22	185	154	165	175	187	194	203	212
	300	250	266	281	298	309	322	335
	500	424	450	476	505	523	545	567

\* Flow rates may vary slightly by wall thickness and spacing



*White Stripe that helps in proper installation*

## T-Tape Drip Tape

One of the most recognized and trusted drip tape brands in the world, T-Tape Drip Tape is used in a variety of crops around the world. T-Tape Drip Tape can be installed on the ground, under opaque plastic, or even subsurface. Because of T-Tape's material strength, design, and quality production standards, you can count on T-Tape year after year.



### Product Information

Turbulent flow dripper technology  
White stripe (easier installation)  
Self-closing slit outlet (ideal for SDI systems)



### Product Options

Diameters: 16, 22, 29 mm  
Wall thickness: 5–15 mil  
Dripper spacings: 10–90 cm  
Flow rate per outlet: 0,25–1,35 lph  
Flow rates at 0,55 bar: 90–1350 lph/ 100 m  
Rolls per pallet: 20



### Operating Guidelines

Standard operating pressure: 0,55 bar  
Maximum pressure: according to wall thickness

### Filtration Requirements (based on lph/Dripper):

lph/Dripper	Micron	Mesh
<0,65	80	200
0,65–1,2	100	150
>1,2	130	120

### Maximum operation Pressure

Diameter (mm)	Wall (mil)	Maximum operation Pressure (bar)
16	5	0,56
16	6	0,70
16	8, 10, 12, 15	1,05
22	6,7	0,56
22	8	0,70
22	10, 12, 15	1,05
29	8	0,56

**T-Tape Drip Tape – Product Specifications/Options\***

Diameter	Wall Thickness	Dripper Spacing	Flow Rate (@0,55 bar)	Roll Length**
(mm)	(mil)	(cm)	(lph / 100m)	(m)
16	5	10, 15, 20, 30	90, 125, 170, 250, 340, 380, 500, 750	3658, 3962
	6	10, 15, 20, 30, 40	125, 170, 250, 340, 380, 500, 750, 1000, 1350	3050
	7	10, 15, 20, 30	250, 500, 1000, 1350	1400, 2800
	8	10, 15, 20, 30, 40	125, 170, 190, 250, 340, 380, 500, 750, 1000, 1350	500, 1150, 2300
	10	10, 15, 20, 30, 40, 60, 90	170, 230, 250, 340, 380, 500, 750, 1000	1830
	12	12, 20, 30	250, 340, 500	1550
	15	20, 30, 40, 50	185, 250, 315, 340, 380, 500	1250
22	6	15, 20, 25, 30	170, 250, 300, 340, 500	2250
	7	20, 30	250, 340, 500	1972
	8	20, 30	170, 250, 340, 380, 500	1695
	10	15, 20, 30	170, 250, 340, 380, 500	1220, 1340
	12	12, 20, 30	170, 250, 340, 500	1135
29	8	30	170, 185, 210, 250, 315, 340	823, 915, 1585
			250, 340	1700

\* Not all configuration available. See price book for available configurations

\*\* Average Roll Weight: 29 Kg.

**Maximum Drip Tape Run (m) on Flat Terrain - Flow Variation: EU 90%, 0,55 bar**







Diameter	Spacing	Flow Rate	Max. Length of Run
(mm)	(cm)	(lph)	(m)
16	10	1350	61
	15	1000	82
	15	170	203
	20	500	115
	20	380	138
	20	250	178
	20	125	245
	30	340	150
	30	250	180
	30	170	233
	50	380	140
22	20	500	205
	30	340	265
	30	250	315
29	30	250	483
	30	340	407

For length of run technical data, see the T-Tape Drip Tape Performance Specifications sheet.







**T-Tape Drip Tape – Flow Vs. Pressure (lph)**

Diameter (mm)	Nominal Flow Rate (lph / 100m)	Flow Rate (lph / 100m)						
		@ 0,4 bar	@ 0,44 bar	@ 0,49 bar	@ 0,55 bar	@ 0,59 bar	@ 0,64 bar	@ 0,69 bar
16	125	104	111	118	125	130	136	142
	170	139	148	157	167	173	181	189
	230	174	185	195	206	213	222	230
	250	206	221	234	250	261	273	285
	340	282	299	316	334	346	360	373
	380	308	329	349	371	386	403	420
	500	423	449	473	501	518	540	560
22	750	617	658	697	742	771	806	839
	170	139	148	157	167	173	181	189
	210	172	184	195	207	216	225	235
	250	206	219	232	247	257	269	280
	340	282	299	316	334	346	360	373

**Connecting PE Hose Manifold Directly To Drip Tape**

Application	Image	Description	Item Number
		Pro-Grip 5/8" tape x 540 Barb	101041881
		Pro-Grip 5/8" tape x 400 Barb	101001144
		Pro-Grip 5/8" tape x 400 Barb w/ Valve	101008189
		Pro-Grip 5/8" tape x 450 Barb	101041880
		Pro-Grip 5/8" tape x 700 Barb	101001146
		Pro-Grip 7/8" tape x 700 Barb	101001174

**Connecting PVC or HDPE Pipe to Barb Fitting or Drip Tape**













Application	Image	Description	Item Number
		Take off grommet, 15 mm, T style 5/8"	101001104
		Take off grommet, 15 mm, H style 5/8"	101001102
		Take off grommet, 17 mm, T style 11/16"	101001105
		Take off grommet, 19 mm, T style	101001106
		5/8" Tape x 425 barb w/ Valve- rubber	101001846
		5/8" Tape x 500 barb w/ Valve- grommet	101001847

### Connecting PVC Layflat Hose To Drip Tape or Small PE Lead Line

Application	Image	Description	Item Number
		Pro-Grip 5/8" Tape x Lay flat	101001154
		Pro-Grip 7/8" Tape x Lay flat	101000851
		Pro-Grip Layflat x 3/4" FPT Swivel w/Washer	101001117
		Pro-Grip 5/8" Tape x 3/4" MPT w/ Valve	101001850

\* Grommets to be use with barbed fittings

**Connecting Drip Tape to Drip Tape or to Miscellaneous Connections**

Application	Image	Description	Item Number
		Pro-Grip 5/8" tape coupling	101001157
		Pro-Grip 5/8" tape x 5/8" tape w/ Valve	101001851
		Pro-Grip 7/8" tape coupling	101001180
		Pro-Grip 5/8" tape coupling x 1/2" Socket	101001161
		Pro-Grip 5/8" tape coupling x 3/4" MPT	101001160
		Pro-Grip 5/8" tape coupling Tee	101001162
		Pro-Grip 5/8" tape coupling x 520 Barb	101001158
		Pro-Grip 5/8" tape x 1/2" MPT	101001156
		5/8" Tape x 3/4" FPT w/ Washer	101001152
		Pro-Grip 7/8" tape x 1/2" Socket	101001179
		Pro-Grip 5/8" tape coupling test	101001147
		Pro-Grip 7/8" tape end test	101001176

### Connecting to the End of Drip Tape Lateral

Application	Image	Description	Item Number
		Tape flush and ends	101001154
		Tape drain valve 3/4" F (for 300/500/700 series)	101001178
		Pro-Grip 5/8" tape end test	101001149
		Pro-Grip 7/8" tape coupling test	101001175



*Retracting splash plate for protection against insects  
Flow regulating membrane*

## Jet+ Jet Stream Spray



### Product Information

No moving parts

Splash plate retracts and seals water outlet to protect nozzle when not in operation

Low angle jet streams

Applications: Standard – Under tree irrigation in fruit orchards, Flow regulated – long laterals or sloping terrain



### Product Options

Standard or flow regulated models

Nominal flow rates (@2 bar):

Standard – 30, 39, 51, 64, 75, 102 lph

Flow regulated – 23, 30, 41, 53, 70, 95 lph

Nominal Wetting diameter:

Standard – 4,2 to 8,6 m

Flow Regulated – 3,2 to 6,4 m

Spray pattern / Jets Configurations:

180/9 jets, 300/14 jets, 360/14 jets

Inlet Connections: 5 mm thread (Standard model),

3/8" Thread (Standard or flow regulated models)



### Operating Guidelines

Operating pressure range: standard models: 1,5–3,0

Flow regulated models: 1,5–3,5

### Filtration Requirements (based on lph/Dripper):

lph/Dripper	micron	mesh
≥40	130	120
>40–70	200	80
>70	250	60

**Jet+ – Maximum Recommended No. of Sprays Per Irrigation Lateral**

Nozzle	Nozzle Color & Size	Wetting Diameter	Emitter Spacing	Pipe Diameter (mm)		
				Outside Diameter / Inside Diameter		
				16 / 13,6	17,8 / 15,2	20 / 17,4
(lph)	(mm)	(m)*	(m)	(Number of sprays)		
30	Light Blue (0,76)	4,2	3	21	25	32
			4	19	23	29
			5	17	21	27
39	Black (0,86)	4,6	3	20	24	31
			4	18	22	27
			5	16	20	25
51	Blue (1,0)	5,4	4	14	18	22
			5	13	16	21
			6	12	15	19
64	Dark Blue (1,1)	5,8	4	12	15	19
			5	11	13	17
			6	10	12	16
75	Green (1,2)	7,0	4	10	13	17
			5	10	12	15
			6	9	11	14
102	Red (1,4)	8,6	4	8	10	13
			5	8	10	12
			6	7	9	12

\* Nozzle at 25 cm above ground level, 360° Spray pattern, flow rate at 2,0 bar

### JFR – Maximum Recommended No. of Sprays Per Irrigation Lateral

Nozzle Size	Nozzle Color	Flow Rate	Wetting Diameter	Emitter Spacing	Pipe Diameter (mm)								
					OD 16 / ID 13,6			OD 17,8 / ID 15,2			OD 20 / ID 17,4		
					Lateral Inlet Pressure (bar)								
(mm)		(lph)	(m)*	(m)	1,6	2,0	3,0	1,6	2,0	3,0	1,6	2,0	3,0
					(Number of sprays)								
0,85	Black	23	3,2	3	15	27	40	18	33	49	23	42	62
				4	14	25	37	17	30	44	21	38	56
				5	13	23	34	16	28	41	20	35	52
1,0	Blue	30	4,0	3	13	24	36	16	29	43	20	36	54
				4	12	21	32	15	26	39	18	33	49
				5	11	20	30	13	24	36	17	30	45
1,1	Dark Blue	41	4,0	3	11	20	29	13	24	35	17	30	45
				4	10	18	26	12	21	32	15	27	40
				5	9	16	24	11	20	29	14	25	37
1,2	Green	53	4,4	4	8	15	22	10	18	27	13	23	34
				5	8	14	21	9	17	25	12	21	31
				6	7	13	19	9	16	23	11	20	29
1,4	Red	70	6,4	4	7	13	19	8	15	23	11	19	29
				5	6	12	17	8	14	21	10	18	26
				6	6	11	16	7	13	20	9	17	25
1,6	White	95	6,4	4	5	9	14	6	11	17	8	14	22
				5	4	8	13	5	10	16	7	13	20
				6	4	8	12	5	10	15	7	12	19

\* Nozzle at 25 cm above ground level, 360° Spray pattern, flow rate at 2,0 bar



*Stake configuration*

## Tornado ray jet stream spray



### Product Information

Unique vortex mechanism allows significantly large water passages minimizing clogging

No moving parts to break, jam, or wear out

Applications: Under tree irrigation in fruit orchards



### Product Options

Nominal Flow rates (at 1,5 bar):

25 (28 for the Take-apart), 34, 55, 70 lph

Spray pattern / Jet configurations:

180° / 8 jets, 300° / 10 jets , 360° / 12 stream jets

Wetting diameter: 2,4-4,2 m according to flow rate

Inlet Connections: 5 mm thread, male conic



### Operating Guidelines

Operating pressure range: 1,5-3,0 bar

### Filtration Requirements (based on lph/Dripper):

lph/Dripper	micron	mesh
≥40	130	120
>40-70	200	80
>70	250	60

### Tornado Ray Jet Steam Spray – Product Specifications/Options

Product	Streams	Spray Patten	Nominal Flow Rates	Nozzle Color & Size
		(degree)	(lph)	(mm)
Tornado Ray Jet	8	180	25,0	Black (0,9)
			34,0	Blue (1,3)
			55,0	Green (1,7)
			70,0	Red (2,0)
Tornado Ray Jet	10	300	25,0	Black (0,9)
			34,0	Blue (1,3)
			55,0	Green (1,7)
			70,0	Red (2,0)
Tornado Ray Jet	12	360	25,0	Black (0,9)
			34,0	Blue (1,3)
			55,0	Green (1,7)
			70,0	Red (2,0)

### Maximum No. of Sprays on Irrigation Laterals (+/- 5% Flow Variation)

Nominal Flow Rate	Nozzle color	Wetting Diameter	Hose Size		Spacing Between Sprays (m)									
			ID	OD	0,20	0,25	0,30	0,35	0,40	0,45	0,50	0,55	0,60	0,65
(lph)		(m)	(mm)	(mm)	(Number of sprays)									
25	Black	2,4	13,6	16	26	24	22	21	20	19	18	18	17	16
			15,2	17,8	32	29	27	26	24	23	22	22	21	20
			17,4	20	40	37	34	33	31	30	28	27	27	26
34	Blue	3,2	13,6	16	20	19	18	17	16	15	14	14	13	13
			15,2	17,8	25	23	21	20	19	18	18	17	16	16
			17,4	20	32	29	27	26	25	23	23	22	21	20
55	Green	3,6	13,6	16	15	14	13	12	12	11	11	10	10	10
			15,2	17,8	19	17	16	15	14	14	13	13	12	12
			17,4	20	24	22	21	19	18	18	17	16	16	15
70	Red	4,2	13,6	16	14	13	12	11	11	10	10	10	9	9
			15,2	17,8	18	16	15	14	13	13	12	12	11	11
			17,4	20	22	21	19	18	17	16	16	15	15	14

\* Inlet pressure: 1,5 bar

\*\* Upright position, 25 cm above ground (360°-12 jet streams)

**Tornado Ray Jet Stream Spray – Flow by Pressure (lph)**

Product	Nominal Flow Rate (lph)	Nozzle Color	Pressure 1,5 bar (lph)	Pressure 2,0 bar (lph)	Pressure 2,5 bar (lph)
Tornado Ray Jet	25	Black	25,6	29,5	33,0
Tornado Ray Jet / Tornado Ray Jet Take Apart	34	Blue	33,9	39,8	45,1
Tornado Ray Jet / Tornado Ray Jet Take Apart	55	Green	55,7	64,3	71,8
Tornado Ray Jet / Tornado Ray Jet Take Apart	70	Red	73,3	79,3	87,0
Tornado Ray Jet Take Apart	28	Black	28,0	32,4	36,0



*Fine droplets prevent water run-off*

## Rondo Medium-Range Micro Sprinkler and RFR Flow Regulated Micro Sprinkler



### Product Information

Low to moderate flow rates and fine droplets prevent water run-off

Constant flow rate over a wide pressure range (RFR)

Applications:

Rondo: Inverted in greenhouses, under tree in orchards, and on metal stakes in vegetables fields

RFR: Under tree irrigation on sloping terrain

Flow rates: Rondo: 51–300 lph, RFR: 23–95 lph

Effective wetting diameter:

Rondo: 4,4–11,0 m, RFR: 5,0–7,0 m

Static deflectors: 90°, 180°, 360°



### Product Options

Flow rates (2,0 bar) –

Rondo: 30, 39, 51, 75, 64, 102, 132, 174, 254, 298 lph

RFR: 23, 30, 41, 53, 70, 95 lph

Inlet Connections –

Ultra female conic, 3/8" Thread (RFR), 5 mm Thread

Spinners –

Wide range of spinner options for Rondo and Rondo Flow Regulated, for standard upright and inverted,

Attachments: Anti-ant cup



### Operating Guidelines

Operating pressure ranges:

Rondo: 1,5–2,5 bar, RFR: 1,5–3,5 bar

### Rondo Medium-Range Micro Sprinkler and RFR Flow Regulated

Product	Nominal Flow Rates (lph)	Spinner	Inlet Connections
Rondo Micro Sprinkler	51, 75, 102, 132, 174, 205	Standard upright: Black (convex), Violet (flat), Black (with Integral range limiter) Inverted: Green (Convex), Blue (flat)	Ultra conic female, 3/8" Thread, 5 mm thread
RFR Flow Regulated Micro Sprinkler	23, 30, 41, 53, 70, 95	Standard upright: Grey (convex), Grey, (with Integral range limiter) Inverted: Red	3/8" thread

### Rondo Medium-Range Micro Sprinkler – Effective Wetting Diameter by Nozzle/Spinner Combination

Product	Nozzle Color & Size	Flow Rate	Black (upright)	Green (inverted)	Blue (inverted)
			Effective Wetting Diameter		
	(mm)	(m)	(m)		
Rondo Micro Sprinkler	Black (0,85)	39	5,8	8,7	8,0
	Blue (1,0)	51	6,6	8,7	8,0
	Dark Blue (1,1)	64	7,6	8,7	8,0
	Green (1,2)	75	8,8	9,8	8,5
	Red (1,4)	102	9,4	10,7	9,5
	White (1,6)	132	10,0	10,8	9,5
	Violet (1,8)	174	10,5	11,2	10,0
	Yellow (2,0)	205	11,0	11,5	—
RFR Flow Regulated Micro Sprinkler	Black (0,85)	23	5,0	—	—
	Blue (1,0)	30	5,5	—	—
	Dark Blue (1,1)	41	6,5	—	—
	Green (1,2)	53	6,5	—	—
	Red (1,4)	70	7,0	—	—
	White (1,6)	95	7,0	—	—

Pressure: Rondo Micro Sprinkler: 2,0 (bar), RFR (Flow Regulated Micro Sprinkler): 1,5–3,5 bar

Upright position: 25 cm above ground level

Inverted position: 200 cm above ground level

\* Black spinner with integral range limiter, wetting diameter: 0,9–1,6 m

Grey spinner with integral range limiter, wetting diameter: 1,0–2,0 m

**Rondo Micro Sprinkler – Maximum No. of Sprinklers per Irrigation Lateral**

Nominal Flow Rate	Nozzle Color	Hose Size		Spacing Between Sprinklers (m)					
		ID	OD	3	4	5	6	7	8
(lph)		(mm)	(mm)	(Number of Sprinklers)					
39	Black	13,6	16	20	18	16	15	14	13
		15,2	17,8	24	22	20	18	17	17
		17,4	20	31	27	25	24	22	21
51	Blue	13,6	16	16	14	13	12	11	11
		15,2	17,8	20	18	16	15	14	13
		17,4	20	25	22	21	19	18	17
64	Dark Blue	13,6	16	13	12	11	10	10	9
		15,2	17,8	16	15	13	12	12	11
		17,4	20	21	19	17	16	15	14
75	Green	13,6	16	12	10	10	9	8	8
		15,2	17,8	14	13	12	11	10	10
		17,4	20	18	17	15	14	13	13
102	Red	13,6	16	10	8	8	7	7	6
		15,2	17,8	12	10	10	9	8	8
		17,4	20	15	13	12	12	11	10
174	Violet	13,6	16	10	9	8	8	7	7
		15,2	17,8	15	14	13	12	11	11
		17,4	20	24	22	20	19	18	17
205	Yellow	13,6	16	9	8	7	7	6	6
		15,2	17,8	14	13	12	11	10	10
		17,4	20	22	20	18	17	16	15

**RFR Micro Sprinkler – Maximum No. of Sprinklers per Irrigation Lateral**

Nominal Flow Rate	Nozzle Color	Hose Size		Spacing Between Sprinklers (m)					
		ID	OD	3	4	5	6	7	8
(lph)		(mm)	(mm)	(Number of Sprinklers)					
23	Black	13,6	16,0	27	25	23	—	—	—
		15,2	17,8	33	30	28	—	—	—
		17,4	20,0	42	38	35	—	—	—
30	Blue	13,6	16,0	24	21	21	—	—	—
		15,2	17,8	29	26	24	—	—	—
		17,4	20,0	36	33	30	—	—	—
41	Dark Blue	13,6	16,0	20	18	16	—	—	—
		15,2	17,8	24	21	20	—	—	—
		17,4	20,0	30	27	25	—	—	—
53	Green	13,6	16,0	17	15	14	13	—	—
		15,2	17,8	20	18	17	16	—	—
		17,4	20,0	25	23	21	20	—	—
70	Red	13,6	16,0	—	13	12	11	—	—
		15,2	17,8	—	15	14	13	—	—
		17,4	20,0	—	19	18	17	—	—
95	White	13,6	16,0	—	9	8	8	—	—
		15,2	17,8	—	11	10	10	—	—
		17,4	20,0	—	14	13	12	—	—



*Flow Regulated model*

## S2000 Micro Sprinkler



### Product Information

Added feature of flow regulation extending the use of the sprinklers in applications with sloping fields or long lateral runs

The S2000 Micro Sprinkler can be installed in combination with a plastic stake, metal stake, or and hanging assembly

Optional range limiter reduces diameter of Spray pattern

Applications: Short-term crops such as vegetables and long-term crops such as orchards

Flow rates: Standard: 29–300 lph

Flow regulated: 24–95 lph

Effective wetting diameter:

Standard: 6,5–10,5 m, Flow regulated: 5–7,5 lph



### Product Options

Nominal flow rates (2,0 bar)

Standard: 29, 37, 51, 61, 75, 97, 125 lph

Flow regulated: 24, 31, 41, 53, 70, 95 lph

Inlet type options:

3/8" Thread / 5mm threaded / conic

Spinners: standard: Black / Dark Blue

Flow regulated: Grey

Attachments: Spinner with removable range limiter,

Trunk Protector diverts the spray pattern away from the trunk, keeping it dry,



### Operating Guidelines

Operating pressure ranges

Standard: 1,5–2,5 bar

Flow regulated: Black, Blue, Dark blue, Red and Green

nozzles: 1,5–3,5 bar

White: 1,75–3,5 bar

## S2000 Micro Sprinkler / Flow Regulated Micro Sprinkler – Specifications/Options

Nominal Flow Rate (lph)	Nozzle Color	Spinner	Inlet Connections	Effective Wetting Diameter	
				Standard (m)	With Range Limiter (m)
29	Light Blue	Black	Threaded: 3/8" / 5mm	6,5	1,0
37	Black		Threaded: 3/8" / 5mm	6,0	1,0
51	Blue		Threaded: 3/8" / 5mm	6,5	1,4
61	Dark Blue		Threaded: 3/8" / 5mm	7,0	1,4
75	Green		Threaded: 3/8" / 5mm	8,0	1,4
97	Red		Threaded: 3/8" / 5mm	9,0	1,4
125	White		Threaded: 3/8" / 5mm	10,0	2,0
170	Violet	Dark Blue	Threaded: 3/8" / 5mm	9,5	—
205	Yellow		Threaded: 3/8" / 5mm	10,0	—
260	Brown		Threaded: 3/8" / 5mm	10,0	—
300	Orange		Threaded: 3/8" / 5mm	10,5	—
24	Black	Grey	Threaded: 3/8"	5,0	1,0-1,5
31	Blue		Threaded: 3/8"	5,0	1,0-1,5
41	Dark Blue		Threaded: 3/8"	5,5	1,0-1,5
53	Green		Threaded: 3/8"	6,0	1,0-1,5
70	Red		Threaded: 3/8"	7,0	1,0-1,5
95	White		Threaded: 3/8"	7,5	1,0-1,5

## S2000 Micro Sprinkler / S2000 Flow Regulated Micro Sprinkler – Maximum No. of Sprinklers per Irrigation Lateral (2 bar, 0% slope, 10% Flow Rate Variation)

Nominal Flow Rate (lph)	Nozzle Color	Hose Size		Spacing Between Sprinklers (m)					
		ID (mm)	OD (mm)	3	4	5	6	7	8
29	Light Blue	13,6	16,0	23	21	19	18	17	16
		15,2	17,8	28	25	23	22	20	19
		17,4	20,0	36	32	30	28	26	25
37	Black	13,6	16,0	20	18	16	15	14	13
		15,2	17,8	24	21	20	18	17	16
		17,4	20,0	30	27	25	23	22	21
51	Blue	13,6	16,0	16	14	13	12	11	11
		15,2	17,8	19	17	16	15	14	13
		17,4	20,0	25	22	20	19	18	17
61	Dark Blue	13,6	16,0	23	21	19	18	17	16
		15,2	17,8	28	25	23	22	20	19
		17,4	20,0	36	32	30	28	26	25
75	Green	13,6	16,0	12	11	10	9	9	8
		15,2	17,8	15	13	12	11	11	10

**S2000 Micro Sprinkler / S2000 Flow Regulated Micro Sprinkler – Maximum No. of Sprinklers per Irrigation Lateral (2 bar, 0% slope, 10% Flow Rate Variation) (continuance)**

Product	Nominal Flow Rate	Nozzle Color	Hose Size		Spacing Between Sprinklers (m)							
			ID	OD	3	4	5	6	7	8		
	(lph)		(mm)	(mm)	(Number of Sprinklers)							
S2000 Micro Sprinkler	75	Green	17,4	20,0	19	17	16	15	14	13		
			97	Red	16,0	13,6	10	9	8	8	7	7
					17,8	15,2	12	11	10	9	9	8
	125	White	20,0	17,4	16	14	13	12	11	11		
			16,0	13,6	8	8	7	6	6	6		
			17,8	15,2	10	9	9	8	7	7		
	S2000 Flow Regulated Micro Sprinkler	24	Black	20,0	17,4	13	12	11	10	10	9	
				13,6	16,0	20	19	17	16	15	14	
				15,2	17,8	25	23	21	20	18	17	
31		Blue	17,4	20,0	32	29	27	25	24	22		
			13,6	16,0	17	16	14	14	13	12		
			15,2	17,8	21	19	17	17	16	15		
41		Dark Blue	17,4	20,0	27	24	23	21	20	19		
			13,6	16,0	15	14	12	11	11	11		
			15,2	17,8	18	16	15	14	13	13		
53		Green	17,4	20,0	27	23	22	20	20	19		
			13,6	16,0	13	11	11	10	9	9		
			15,2	17,8	15	14	13	12	11	11		
70		Red	17,4	20,0	19	17	16	15	14	14		
			13,6	16,0	10	9	8	7	8	7		
			15,2	17,8	9	7	8	7	6	6		
95		White	17,4	20,0	16	15	14	13	12	12		
			13,6	16,0	6	5	5	5	5	4		
			15,2	17,8	8	7	6	5	6	6		
				17,4	203	10	8	7	8	7	7	



*Plastic Impact Sprinkler is designed with a non-corrosive body with a stainless steel spring for durability*

## S5000 Plastic Impact Sprinkler



### Product Information

Plastic Impact Sprinkler is designed with a non-corrosive body with a stainless steel spring for durability  
Non-corrosive body with a stainless steel spring  
Sprinkler cover to protect against sand and dirt  
Bayonet nozzles for easy field maintenance or replacement,

Flow rates:

Flow rates at 2,5 bar:

Low angle: 375–637 lph, High angle: 390–1286 lph

High Angle Partial Circle: 407–786 lph

Applications: Low angle: Orchards (under tree irrigation) and shade houses, High angle: Open fields (overhead irrigation) and germination of vegetables, flowers, and nursery crops, High Angle Partial Circle: for field edges



### Product Options

Number of nozzles: 1 or 2

Angle of nozzles: Low 9°, Low 12°, low 14°, and High 24°

Nozzle / rotor combinations

Connection options: 1/2" Male thread



### Operating Guidelines

Operating pressure range: 2,0–4,0 bar

### Filtration Requirements (based on lph/Sprinkler):

lph/Sprinkler	micron	mesh
All	250	60

### S5000 Plastic Impact Sprinkler – Effective Wetting Diameter and Flow Rate by Nozzle/Spinner Combination, 2,5 bar

Nozzle Angle	Nozzle Color	Nozzle Size (mm)	9°		12°		14°	
			Flow Rate (lph)	Wetting Diameter (m)	Flow Rate (lph)	Wetting Diameter (m)	Flow Rate (lph)	Wetting Diameter (m)
Low	Violet	2,5	375	17,0	408	17,0	379	17,0
	Orange	2,9	485	17,5	507	18,0	488	17,5
	Green	3,2	635	16,5	637	17,5	629	18,5

Nozzle Angle	Nozzle Color	Nozzle Size (mm)	24°*	
			Flow Rate (lph)	Wetting Diameter (m)
High	Yellow x Plug	2,6	390	19,5
	Orange x Plug	2,9	502	22,5
	Green x Plug	3,2	625	23,5
	Blue x Plug	3,5	774	22,0
	Black x Plug	4,0	9,55	23,0
	Grey x Light Green	2,3 x 1,8	509	22,0
	Yellow x Light Green	2,6 x 1,8	564	19,0
	Orange x Light Green	2,9 x 1,8	676	21,5
	Green x Light Green	3,2 x 1,8	806	22,5
	Blue x Yellow	3,5 x 2,2	1147	20,5
Black x Yellow	4,0 x 2,5	1286	23,5	

Nozzle Angle	Nozzle Color	Nozzle Size (mm)	24°*	
			Flow Rate (lph)	Wetting Diameter (m)
High Angle Partial Circle	Violet	2,2	407	22
	Orange	2,9	509	23
	Green	3,2	630	23
	Blue	3,5	786	21,5

### S5000 Plastic Impact Sprinkler – Maximum Recommended No. of Sprinklers on Irrigation Laterals (Maximum Flow Rate Variation – 10%)

Nozzle Angle	Nominal Flow Rate	Nozzle Color	Hose Size		Spacing Between Sprinklers (m)							
			ID	OD	8	9	10	11	12	13	14	15
	(lph)		(mm)	(mm)	(Number of Sprinklers)							
Low 9°	375	Purple	45,6	50	8	27	26	25	24	23	23	22
	485	Orange	45,6	50	23	22	22	21	20	19	19	18
	635	Green	45,6	50	20	19	18	18	17	17	16	16
Low 12°	408	Purple	45,6	50	26	25	24	23	23	22	21	21
	507	Orange	45,6	50	23	22	21	20	20	19	18	18
	637	Green	45,6	50	20	19	19	18	17	17	16	16
Low 14°	379	Purple	45,6	50	28	27	25	25	24	23	22	22
	488	Orange	45,6	50	23	22	21	21	20	19	19	18
	629	Green	45,6	50	20	19	19	18	17	17	16	16
High 24°	390	Yellow x Plug	45,6	50	28	26	25	24	24	23	22	22
	502	Orange x Plug	45,6	50	23	22	21	20	20	19	19	18
	625	Green x Plug	45,6	50	20	19	18	18	17	17	16	16
	774	Blue x Plug	45,6	50	17	17	16	15	15	14	14	14
	509	Gray x Light Green	45,6	50	23	22	22	21	20	19	19	18
	564	Yellow x Light Green	45,6	50	22	21	20	19	19	18	17	17
	676	Orange x Light Green	45,6	50	19	18	18	17	16	16	15	15
	806	Green x Light Green	45,6	50	17	16	15	15	14	14	13	13
	1147	Blue x Yellow	45,6	50	13	13	12	12	11	11	11	10



*Slow rotating rotor*

## Super XL Sprinkler



### Product Information

Slow rotating rotor produces a single continuous water jet stream, and creates a uniform wetting pattern

Easy to assemble and dismantle

May be mounted on 3/8" or 1/2" PVC risers, or used with Rivulis Meteor adapters on plastic sprinkler stakes with adapter end or 8 mm metal rods

Flow rates (2,5 bar): 191, 235, 290, 341 lph

Wetting diameter: 15,0–17,0 m, according to flow rate



### Product Options

Inlet type options:

3/8" Male thread

1/2" Male thread



### Operating Guidelines

Operating pressure range: 2,5–3,5 bar (at sprinkler base)  
(Purple nozzle minimum pressure range: 3,0 bar)

### Filtration Requirements (based on lph/Sprinkler):

lph/Sprinkler	micron	mesh
All	200	80

### Super XL Sprinkler – Product Specifications/Options

Product	Nominal Flow Rates (lph)	Nozzle Color & Size (mm)	Rotor	Inlet Connections
Super XL Sprinkler	191	Violet (1,8)	Brown w/Blue cover	3/8" Male thread, 1/2" male thread
	235	Yellow (2,0)		
	290	Brown (2,2)	Brown w/Green cover	
	341	Orange (2,4)		

Pressure: at 2.5 bar

### Super XL Sprinkler – Maximum Recommended no. of Sprinklers on Irrigation Laterals

Nominal Flow Rate (lph)	Nozzle Color	Hose Size (mm)	Spacing Between Sprinklers (m)			
			6	7	8	9
191	Violet	40 / 36,6	32	31	29	28
235	Yellow		28	27	25	24
290	Brown		25	23	22	21
341	Orange		22	21	20	19

### Super XL – Performance Data

Nozzle Color & Size (mm)	Pressure (bar)	Flow Rate (lph)	Wetting Diameter*		Application Rate (mm/h)**													
			Brown Rotor		Spacing (mxm) – Rectangular Layout ***													
			Blue Cover	Green Cover	6x6	6x7	6x8	6x9	6x10	7x7	7x8	7x9	7x10	8x8	8x9	8x10	9x9	9x10
Violet 1,8	3,0	209	16,5	–	5,8	5,0	4,4	3,9	3,5	4,3	3,7	3,3	3,0	3,3	2,9	2,6	2,6	2,3
	2,5	235	15,5	–	6,5	5,6	4,9	4,4	3,9	4,8	4,2	3,7	3,4	3,7	3,3	2,9	2,9	2,6
Yellow 2,0	3,0	258	16,5	–	7,2	6,1	5,4	4,8	4,3	5,3	4,6	4,1	3,7	4,0	3,6	3,2	3,2	2,9
	2,5	290	–	17,0	8,1	6,9	6,0	5,4	4,8	5,9	5,2	4,6	4,1	4,5	4,0	3,6	3,6	3,2
Brown 2,2	3,0	315	–	16,0	8,8	7,5	6,6	5,8	5,3	6,4	5,6	5,0	4,5	4,9	4,4	3,9	3,9	3,5
	2,5	341	–	17,0	9,5	8,1	7,1	6,3	5,7	7,0	6,1	5,4	4,9	5,3	4,7	4,3	4,2	3,8
Orange 2,4	3,0	373	–	16,5	10,4	8,9	7,8	6,9	6,2	7,6	6,7	5,9	5,3	5,8	5,2	4,7	4,6	4,1

\* At 75 cm above ground level

\*\* Performance data are obtained under ideal test conditions and may be adversely affected by wind, hydraulic conditions, and other factors,

\*\*\* 8x10, 9x9, 9x10 – Recommended for undertree irrigation



*Vortex nozzle provides a spinning flow and minimizes clogging hazards*

## FLF Flow Regulated Fog Spray



### Product Information

Vortex nozzle provides a spinning flow and minimizes clogging hazards

Available as a single fog spray assembled directly into the anti-leak mini-valve, or 2 and 4-outlet fog sprays compatible with the anti-leak H mini-valve

Applications: Humidification and climate control in greenhouses and high tunnels, cutting propagation and seed germination, and livestock cooling



### Product Options

Flow rates (at 3,5 bar):

light blue – 5,4 lph, dark blue – 10,5 lph

Inlet type options: barb / male conic / female conic



### Operating Guidelines

Operating pressure range: 3,5–5,0 bar

Required opening pressure: 3,5 bar

Sealing pressure: 1,4 bar

### Filtration Requirements (based on lph/Spray):

lph/Spray	micron	mesh
All	100	150

**FLF Flow Regulated Fog Spray – Product Specifications/Options**

Product	Outlets	Flow Rates Per outlet	Nozzle Color	Inlet Connections	Feature
		(lph)			
FLF Fog Spray Single	1	5,4	Light Blue	Barb	HP anti-leak valve
		10,5	Dark Blue		
		5,4	Light Blue	Male conic	
		10,5	Dark Blue		
FLF Fog Spray 2-Way	2	5,4	Light Blue	Female conic	
		10,5	Dark Blue		
FLF Fog Spray 4-Way	4	5,4	Light Blue		
		10,5	Dark Blue		

**Flow Rate by Pressure (lph)**

Product	Nominal Flow Rate *	Outlet Color	Flow Rate (@ 3,5 bar)	Flow Rate (@ 4,0 bar)	Flow Rate (@ 5,0 bar)
	(lph)		(lph)	(lph)	(lph)
FLF Fog Spray Single	5,4	Light Blue	5,38	5,66	6,18
	10,5	Dark Blue	10,57	11,22	12,38
FLF Fog Spray 2-Way	5,4	Light Blue	10,24	10,82	11,87
	10,5	Dark Blue	20,17	21,36	23,52
FLF Fog Spray 4-Way	5,4	Light Blue	20,17	21,86	23,94
	10,5	Dark Blue	39,74	42,29	46,91

\* Per outlet



## Rondo Mist Sprayer



### Product Information

No moving parts

Detachable bayonet nozzle

Average droplet size: 150 micron

Applications: Seed germination and cutting propagation in nurseries, cooling and increasing humidity in greenhouses



### Product Options

Flow rates (at 3,0 bar): 47, 61 lph

Inlet Connections: Female conic



### Operating Guidelines

Operating pressure range: 2,5–4,0 bar

### Filtration Requirements (based on lph/Dripper):

lph/Dripper	Micron	Mesh
≥40	130	120
>40–70	200	80
>70	250	60

**Rondo Mist Sprayer – Product Specifications/Options**

Product	Nominal Flow Rates	Inlet Connections	Item Number
	(lph)		
Rondo Micro Sprinkler with Mist Feature	47	Female Conic	201000281
	61		101022981

**Maximum no. of Sprinklers on Irrigation Laterals, 3 bar**

Nominal Flow Rate	Nozzle Color & Diameter	Deflector Color	Hose Size		Spacing Between Sprinklers (m)					
			ID	OD	70	90	100	120	140	150
(lph)	(mm)		(mm)	(mm)	(Number of Sprinklers)					
47	Black 0,85	Purple	13,6	16,0	30	28	28	26	25	25
			15,2	17,8	41	38	37	35	34	33
			17,4	20,0	51	48	47	44	42	41
61	Blue 1,0		13,6	16,0	24	22	22	21	20	20
			15,2	17,8	32	30	29	28	27	26
			17,4	20,0	41	38	37	35	33	32

Average wetting diameter: 2,0 m (Overhead inverted position, 70 cm above plant)

**Flow by Pressure (lph)**

Product	Nominal Flow Rate	Outlet Color	Pressure 2,5 bar	Pressure 3 bar	Pressure 4 bar
	(lph)		(lph)	(lph)	(lph)
Rondo Micro Sprinkler with Mist Feature	47	Black	43,1	47,4	55,0
	61	Blue	56,7	62,3	72,3





*Heavy duty screen filter to prevent the penetration of stones and large particles into the water system during operation.*

## Rivulis Pre-Filtration Strainer



### Product Information

The Pre-Filtration Strainer is designed to protect pumps, watermeters, valves, etc. The filter prevents the penetration of stones and large particles into the water system during operation. To get the best results the filter must be correctly installed, properly operated and maintained according to the following instructions: This screen filter prevents the penetration of stones.



### Product Options

Connection size: 3–24" (80–600 mm)

Connection type: BSTD, ISO-16



### Operating Guidelines

Head loss not to exceed: 0,7 bar

Maximum operating pressure: 8,0 bar

Maximum pressure: 10,0 bar

### Pre-Filtration Strainer – Product Specifications/Options

Inlet/Outlet		Connections	Maximum Flow Rate	Screens
(inch)	(mm)		(m <sup>3</sup> /h)	(micron)
3	80	BSTD, ISO-16	40	3000
4	100	BSTD, ISO-16	65	3000
6	150	BSTD, ISO-16	150	3000
8	200	BSTD, ISO-16	260	3000
10	250	BSTD, ISO-16	400	3000
12	300	BSTD, ISO-16	580	3000
14	350	BSTD, ISO-16	700	3000
16	400	BSTD, ISO-16	880	3000
18	450	BSTD, ISO-16	1150	3000
20	500	BSTD, ISO-16	1450	3000
24	600	BSTD, ISO-16	2000	3000

### Pre-Filtration Strainer – Head Loss Chart (bar)

Filter Size		Flow Rate (m <sup>3</sup> /h)												
		40	60	80	100	125	150	175	200	250	300	400	500	700
(inch)	(mm)	Head Loss (bar)												
3	80	0,05	0,12	0,21	0,33	0,51	0,73	1,00	—	—	—	—	—	—
4	100	—	0,05	0,08	0,13	0,21	0,3	0,4	0,53	0,83	1,19	—	—	—
6	150	—	—	—	0,04	0,06	0,09	0,12	0,16	0,26	0,37	0,65	1,02	—
8	200	—	—	—	—	—	—	—	0,05	0,07	0,10	0,18	0,28	0,64

### Pre-Filtration Strainer – Head Loss Chart (bar)

Filter Size		Flow Rate (m <sup>3</sup> /h)												
		300	500	750	1000	1250	1500	1750	2000	2500	3000	3500	4500	5500
(inch)	(mm)	Head Loss (bar)												
10	250	0,06	0,17	0,37	0,66	1,03	—	—	—	—	—	—	—	—
12	300	—	0,07	0,16	0,28	0,43	0,62	0,85	1,11	—	—	—	—	—
14	350	—	0,05	0,12	0,21	0,33	0,47	0,64	0,84	—	—	—	—	—
16	400	—	—	0,09	0,16	0,24	0,35	0,47	0,62	0,97	—	—	—	—
18	450	—	—	—	0,07	0,1	0,15	0,2	0,26	0,41	0,59	0,81	—	—
20	500	—	—	—	0,05	0,08	0,11	0,15	0,20	0,31	0,45	0,61	1,01	—
24	600	—	—	—	—	0,04	0,06	0,08	0,11	0,17	0,25	0,34	0,56	0,84

### Pre-Filtration Strainer – Product Specifications/Options

Inlet/Outlet		B	D	A	H	H1	Weight
(inch)	(mm)	(mm)	(inch)	(mm)	(mm)	(mm)	(kg)
3	80	80	6	330	560	292	40
4	100	100	6	330	580	292	45
6	150	150	8	420	610	292	65
8	200	200	10	515	665	294	95
10	250	250	12	565	715	334	120
12	300	300	14	655	795	336	170
14	350	350	16	710	825	378	220
16	400	400	18	760	870	400	275
18	450	450	20	810	890	392	350
20	500	500	24	980	950	417	575
24	600	600	28	1080	1115	503	670

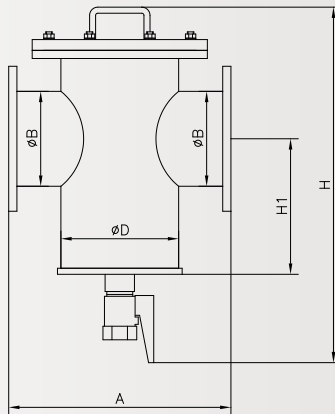

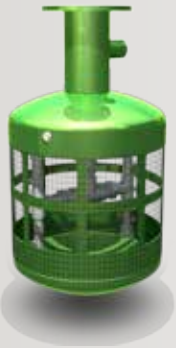

## Rivulis Self-Cleaning Suction Strainer



### Product Information

This strainer has been designed and manufactured to achieve the highest standards of quality and finish. The strainer is used as a preliminary filter to a water pump inlet. Due to its self-cleaning operation, this strainer reduces the pump's maintenance and increases significantly its efficiency. The self-cleaning suction strainer is designed to protect the pump from clogging by debris and solid dirt. It is connected to the pump inlet and submerged in the water source (river, lake, reservoir etc.) The Self-Cleaning Suction Strainer is designed to protect the pump from clogging by debris and solid dirt. It is connected to the pump inlet and submerged in the water source (river, lake, reservoir, etc.)



### Operating Guidelines

Minimum pressure for backflushing: 1,5 bar

### Self-Cleaning Suction Strainer – Product Specifications/Options

Inlet/Outlet		Connections	Screen	Maximum Flow Rate	Flush Flow Rate	Weight		
(inch)	(mm)		(micron)	(m <sup>3</sup> /h)	(m <sup>3</sup> /h)	(kg)		
4	100	BSTD ISO-16	1200	80	5,0	24		
			2500	100				
6	150		1200	180		6,5	35	
			2500	230				
8	200		1200	300			6,5	40
			2500	380				
10	250		1200	420	6,5			57
			2500	550				
12	300		1200	600		6,5		62
			2500	750				
14	350		1200	800			6,5	71
			2500	1000				
16	400	1200	1000	6,5	81			
		2500	1200					

### Self-Cleaning Suction Strainer – Product Dimensions

Size		B	D	C	H	Weight
(inch)	(mm)	(mm)	(inch)	(mm)	(mm)	(kg)
4	100	100	16	40	650	24
6	150	150	20	40	770	35
8	200	200	20	40	970	40
10	250	250	24	40	1040	57
12	300	300	24	40	1240	62
14	350	350	36	40	1340	71
16	400	400	36	40	1340	81

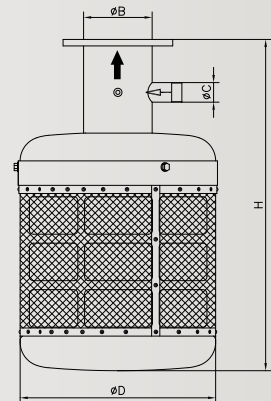



*Available in horizontal and vertical models.*

## Rivulis Fertilizer Tank

Rivulis Fertilizer Tanks have been designed and manufactured to achieve the highest standards of quality and finish. This fertilizer tanks apply fertilizer in accordance with the volume principle. Fertilizing can be performed continuously during irrigation, controlled by controller or computer as required, or may be manually operated. Injecting fertilizer into the irrigation system is generally recommended during the first two thirds of irrigation time, to ensure proper flushing of the irrigation system and to minimize the drippers' clogging by the chemicals residues.



### Product Information

Fertilizer Tanks equipped with Inlet/Outlet high pressure hose (1/2" or 15 mm), quick connections, and air valve



### Operating Guidelines

Maximum recommended operating pressure: 8 bar

Maximum pressure: 10 bar

**Rivulis Fertilizer Tank – Product Specifications/Options**

Body	Capacity	Tank Height	Outlet Height	Length	Weight
	(L)	(mm)	(mm)	(mm)	(kg)
Vertical	60	390	800	—	31
	90	480	800	—	38
	120	480	950	—	44
Horizontal	120	480	750	700	45
	220	480	750	1100	59
	300	610	860	1000	75
	500	750	1110	1300	130

**Rivulis Fertilizer Tank – Fertilizing Times**

Body	Capacity	@ 0,05 bar Pressure Loss	@ 0,1 bar Pressure Loss	@ 0,2 bar Pressure Loss	@ 0,4 bar Pressure Loss
	(L)	(hours)	(hours)	(hours)	(hours)
Vertical	60	1,0–1,25	0,75–1,0	0,50–0,75	0,33–0,50
	90	1,75–2,0	1,25–1,50	0,75–1,0	0,50–0,75
	120	2,0–2,50	1,50–2,0	1,0–1,50	0,75–1,0
Horizontal	120	2,0–2,50	1,50–2,0	1,0–1,50	0,75–1,25
	220	3,75–4,50	2,50–2,75	1,75–2,25	1,25–1,50
	300	5,50–6,50	3,75–4,50	2,75–3,25	1,50–1,75
	500	9,50–10,50	6,75–7,50	5,0–5,25	3,0–3,75



## F1000 Hydrocyclone Sand Separator

The Rivulis F1000 Hydrocyclone Sand Separator creates a centrifugal action that moves the water around the edge of the body, throwing the sand and heavy materials to the outside or the cyclone. The heavy materials then fall into the underflow tank to be collected and removed.



### Product Information

All models include underflow tank collector, legs, rubber, protective cone



### Product Options

Diameters: 1,5" (40 mm) – 8" (200 mm)

Connections: Threaded, Flange, or Grooved



### Operating Guidelines

Operating pressure: 8,0 bar

Maximum pressure: 10,0 bar

Recommended head loss: 0,3–0,5bar

**F1000 Hydrocyclone Sand Separator – Product Specifications/Options**

Inlet/Outlet		Body	Recommend Minimum Flow Rate	Recommended Maximum Flow Rate	Tank Capacity	Connection Type
(inch)	(mm)		(m <sup>3</sup> /h)	(m <sup>3</sup> /h)	(L)	
1,5	40	Standard	7,5	12	10	VIC, BSP
2	50	Standard	11	17	10	VIC, BSP
3	80	Standard	18	34	10	VIC, BSTD, ISO-16
4 In/3 Out	100 In/80 Out	Standard	35	52	60	VIC, BSTD, ISO-16
4	100	Standard	52	82	120	VIC, BSTD, ISO-16
6	150	Standard	98	160	220	VIC, BSTD, ISO-16
6L	150	Long	140	230	220	VIC, BSTD, ISO-16
8	200	Standard	230	360	320	VIC, BSTD, ISO-16

**F1000 Hydrocyclone Sand Separator – Product Head Loss Chart (bar)**

Inlet/Outlet		Head Loss (bar)					
		0,2	0,3	0,4	0,5	0,6	0,7
(inch)	(mm)	Flow Rate (m <sup>3</sup> /hr)					
1,5	40	7,6	9,3	10,8	12,0	13,2	14,2
2	50	10,1	12,4	14,3	16,0	17,5	18,9
3	80	21,1	25,9	29,9	33,4	36,6	39,5
4 In/3 Out	100 In/80 Out	30,4	37,2	43,0	48,1	52,7	56,9
4	100	50,1	61,3	70,8	79,2	86,8	93,7
6	150	96,2	117,8	136,0	152,0	166,5	179,9
6L	150 Long	138,6	169,8	196,1	219,2	240,1	259,4
8	200	216,8	265,6	306,7	342,9	375,7	405,8

### F1000 Hydrocyclone Sand Separator – Product Dimensions and Weights

Inlet/ Outlet – B (inch)	(mm)	D (mm)	H (mm)	H1 (mm)	H2 (mm)	L (mm)	T (mm)	Weight (kg)
1,5	40	150	630*	490*	425	240	61	19
2	50	200	735*	575*	530	295	80	20
3	80	200	830*	660*	625	300	65	27
4/3	100/80	300	1330	1130	725	500	105	66
4	100	400	1720	1480	970	600	145	125
6	150	510	1900	1610	1150	600	170	172
6"L	150	610	2155	1860	1405	600	220	205
8"	200	760	2825	2360	1925	700	265	365

\* Height for underflow chambers without legs

### F1000 Hydrocyclone Sand Separator – Product Dimensions

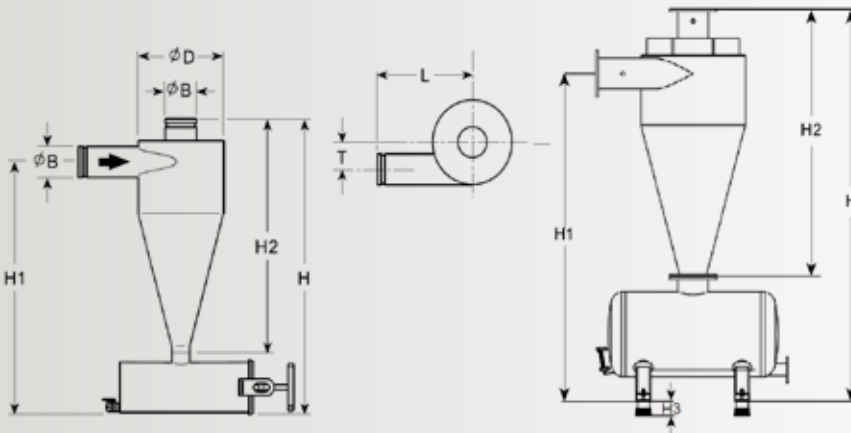



*Double chamber, Precision conical diffusers/collectors*

## F2000 Media Filter

F2000 Media Filters (gravel or sand) are the most efficient type of filtration of water heavily contaminated with algae, organic matter and other impurities found in open reservoirs, canals and recycled water systems. The filtration occurs when the water passes through the open spaces and between sand particles, trapping the solid particles.



### Product Information

3 service ports for maintenance

Double chamber, precision conical diffusers/collectors



### Product Options

Diameters:

1,5" (40 mm) – 16" (400 mm) to 60" (1500 mm)

Connections type: BSP, Grooved, and ISO-16



### Operating Guidelines

Operating pressure: 8,0 bar

Maximum pressure: 10,0 bar

Pressure differential: Not to exceed 0,5 bar

**F2000 Media Filter – Product Specifications/Options**

Body Diameter		Inlet/Outlet		Minimum Flow Rate	Maximum Flow Rate	Back Flush Flow Rate	Connection Type
(inch)	(mm)	(inch)	(mm)	(m <sup>3</sup> /h)	(m <sup>3</sup> /h)	(m <sup>3</sup> /h)	
16	400	2	50	6	11	10	BSP
20	500	2	50	9	18	15	BSP
20	500	3	80	10	18	15	ISO-16, VIC, BSTD
24	600	2	50	14	28	25	BSP, VIC
24	600	3	80	14	28	25	BSTD, VIC, ISO-16
30	750	3	80	21	42	38	BSTD, VIC, ISO-16
36	900	3	80	32	62	54	BSTD, VIC, ISO-16
48	1200	4	100	62	120	95	BSTD, VIC, ISO-16
60	1500	4	100	80	150	150	VIC

\* the data for Basalt no 1

\* for quartz sand 16,20 use half flow rate

\* for dirty water reduce flow rate

**F2000 Media Filter – Amount of Media Required for Each Filter**

Body Model		Inlet Model		Weight
(inch)	(mm)	(inch)	(mm)	(kg)
16	400	2	50	75
20	500	2	50	125
24	600	2	50	175
30	750	3	80	250
36	900	3	80	350
48	1200	4	100	625
60	1500	4	100	1,000

**F2000 Media Filter – Product Dimensions and Weights**

Body Model		Inlet		B	D	H	H1	H2	Weight
(inch)	(mm)	(inch)	(mm)	(mm)	(mm)	(mm)	(mm)	(mm)	(kg)
16	400	2	40	40	400	1250	870	180	50
20	500	2	50	50	500	1250	870	180	70
20	500	3	80	80	500	1400	1,040	180	75
24	600	2	50	50	600	1350	950	260	90
24	600	3	80	80	600	1350	950	260	90
30	750	3	80	80	750	1170	-	360	135
36	900	3	80	80	900	1170	-	360	185
48	1200	4	100	100	1,200	1190	-	360	310
60	1500	4	100	100	1,500	1470	-	510	430

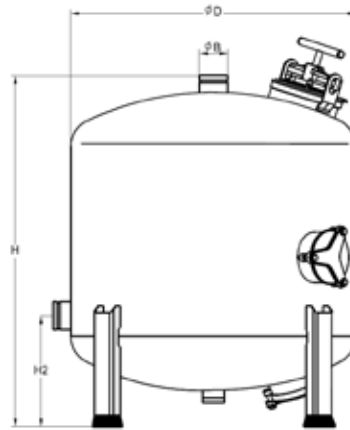
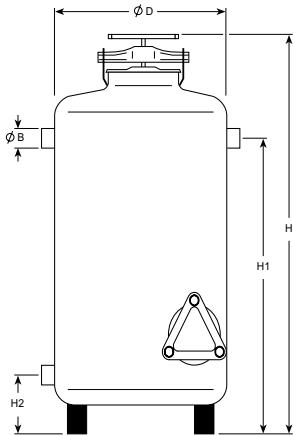



*Used in conjunction with sand separators and media filter arrays as control filters or as back-up filters in the field*

## F3100 Metal Screen Filter (Manual)

The Rivulis F3100 Metal Screen Filters (Manual) are excellent filtration choices for removing hard particulates from water, such as sand, manual screen filters are designed to remove particles from the water by passing the water through an open area in the screen, the dirt particles are collected on the screen and are removed when the filter is opened and the screen is cleaned manually.



### Product Information

Used in conjunction with sand separators and media filter arrays as control filters or as back-up filters in the field  
Excellent filtration choices for removing hard particulates from water



### Product Options

Diameters: 3" (80 mm) – 12" (300 mm)  
Connections type: BSPT, BSTD, Grooved, and ISO-16  
Screen options: 100, 130, 200, 400 micron



### Operating Guidelines

Maximum operating pressure: 8,0 bar  
Maximum pressure: 10,0 bar

**F3100 Metal Screen Filter – Product Head Loss Chart (bar)**

Filter (inch)	Flow Rate (m <sup>3</sup> /h)															
	25	50	100	150	200	250	300	350	400	450	500	600	700	800	900	1000
	Head Loss (bar)*															
3	0,02	0,08	0,31	0,69	1,23	—	—	—	—	—	—	—	—	—	—	—
4	—	0,02	0,08	0,18	0,33	0,51	0,73	1,00	—	—	—	—	—	—	—	—
6	—	—	—	0,06	0,10	0,16	0,23	0,31	0,40	0,51	0,63	0,91	—	—	—	—
8	—	—	—	—	0,04	0,06	0,08	0,11	0,15	0,18	0,23	0,33	0,44	0,6	0,76	0,94
10	—	—	—	—	—	—	0,04	0,06	0,08	0,10	0,12	0,17	0,23	0,32	0,40	0,50
12	—	—	—	—	—	—	—	—	0,05	0,07	0,08	0,12	0,17	0,22	0,28	0,35

\* with 400 micron screen

**Product Specifications/Options**

Inlet/ Outlet		Body	Maximum Flow Rate* (m <sup>3</sup> /h)	Screen (micron)	Connection Type
(inch)	(mm)				
3	80	In-Line, Angled	60	100, 130, 200, 400	BSP, ISO-16, VIC, BSTD
4	100	In-Line, Angled	100	100, 130, 200, 400	ISO-16, VIC, BSTD
6	150	In-Line, Angled	250	100, 130, 200, 400	ISO-16, VIC, BSTD
8	200	In-Line, Angled	350	100, 130, 200, 400	ISO-16, VIC, BSTD
10	250	In-Line, Angled	500	100, 130, 200, 400	ISO-16, VIC, BSTD
12	300	In-Line, Angled	650	100, 130, 200, 400	ISO-16, VIC, BSTD

\* with 400 micron screen

### F3100 Metal Screen Filter – Product Dimensions and Weights

B	D	A	H	T	Weight	
(inch)	(mm)	(mm)	(mm)	(mm)	(kg)	
(In-Line)						
3	80	200	540	600	—	26
4	100	200	565	600	—	27
6	150	250	750	765	—	53
8	200	300	1080	800	—	86
10	250	350	1290	825	—	110
12	300	400	1395	925	—	165
(Angled)						
3	80	215	680	310	26	
4	100	255	680	310	27	
6	150	292	820	460	45	
8	200	292	1060	570	84	
10	250	333	1115	610	105	
12	300	408	1210	780	152	

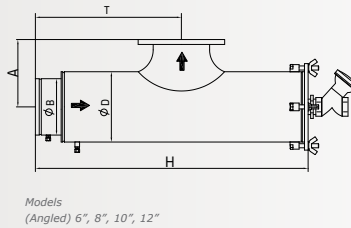
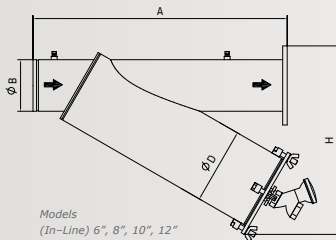
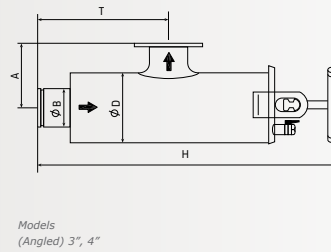
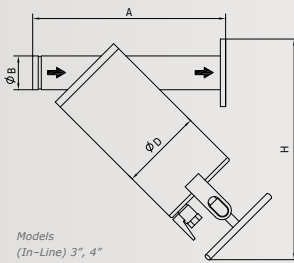



180 micron protective coating  
Sintered screen

## F3200 Metal Screen Filter with Hydraulic Operation

F3200 Metal Screen Filters with Hydraulic Operation are the ideal choice for applications without AC electricity. The F3200 Filters utilizes continuous movement of the collector assembly to remove particles. The standard housing of the filter is made of carbon steel with a minimum 180 micron protective coating of extra durable polyester, applied electrostatically and oven cured on a zinc-phosphate layer, and a sintered or PVC screen to provide maximum anti-corrosion stainless still 316 screen with sintered or PVC support protection both internally and externally.



### Product Information

Used as a primary filter for water containing large quantities of dirt

Ideal for applications without AC electricity



### Product Options

Diameters: 2" (50 mm) – 20" (500 mm)

Connections type: BSPT, BSTD and ISO-16

Screen options: 80, 100, 130, 200 micron

Body styles: angled, parallel, parallel long



### Operating Guidelines

Minimum operating pressure: 2,0 bar

Maximum operating pressure: 8,0 bar

Maximum pressure: 10,0 bar

Duration of flushing for 2", 3", 4" Angle models:  
8–12 seconds

Duration of flushing for 6", 8" Angle models:  
14–16 seconds

**F3200 Metal Screen Filter with Hydraulic Operation – Summary**

Inlet/outlet		Body	Connections	Maximum Flow Rate	Flush Flow Rate Range	Screen Area	Screens	Current Options
(inch)	(mm)			(m <sup>3</sup> /h)	(m <sup>3</sup> /h)	(cm <sup>2</sup> )	(micron)	
2	50	Angle	BSP, BSTD, ISO-16	25	4-5	850	80, 100, 130, 200	AC, DC
3	80	Angle	BSTD, ISO-16	40	4-5	1450	80, 100, 130, 200	AC, DC
4	100	Angle	BSTD, ISO-16	60	4-5	1450	80, 100, 130, 200	AC, DC
4L	100	Angle	BSTD, ISO-16	80	8-10	2360	80, 100, 130, 200	AC, DC
6	150	Angle	BSTD, ISO-16	150	8-10	4500	80, 100, 130, 200	AC, DC
8	200	Angle	BSTD, ISO-16	300	12-14	6200	80, 100, 130, 200	AC, DC
2	50	Parallel	BSP, BSTD, ISO-16	25	11	2500	80, 100, 130, 200	AC, DC
3	80	Parallel	BSTD, ISO-16	40	11	2500	80, 100, 130, 200	AC, DC
4	100	Parallel	BSTD, ISO-16	60	11	2500	80, 100, 130, 200	AC, DC
4L	100	Parallel	BSTD, ISO-16	80	16	4000	80, 100, 130, 200	AC, DC
6	150	Parallel	BSTD, ISO-16	120	16	4000	80, 100, 130, 200	AC, DC
6L	150	Parallel	BSTD, ISO-16	150	16	6000	80, 100, 130, 200	AC, DC
8	200	Parallel	BSTD, ISO-16	200	22	6000	80, 100, 130, 200	AC, DC
8L	200	Parallel	BSTD, ISO-16	300	28	8000	80, 100, 130, 200	AC, DC
10	250	Parallel	BSTD, ISO-16	300	22	6000	80, 100, 130, 200	AC, DC
10L	250	Parallel	BSTD, ISO-16	400	28	8000	80, 100, 130, 200	AC, DC
12	300	Parallel	BSTD, ISO-16	470	28	8000	80, 100, 130, 200	AC, DC
12L	300	Parallel Long	BSTD, ISO-16	600	23	10050	80, 100, 130, 200	AC, DC
14	350	Parallel	BSTD, ISO-16	550	28	8000	80, 100, 130, 200	AC, DC
14L	350	Parallel Long	BSTD, ISO-16	800	23	10050	80, 100, 130, 200	AC, DC
16L	400	Parallel Long	BSTD, ISO-16	1000	23	10050	80, 100, 130, 200	AC, DC
18L	450	Parallel Long	BSTD, ISO-16	1300	23	16150	80, 100, 130, 200	AC, DC
20L	500	Parallel Long	BSTD, ISO-16	1600	23	16150	80, 100, 130, 200	AC, DC

**F3200 (Parallel) – Product Dimensions and Weights**

Size	B	D	A	E	H	L	L1	Weight
(inch)	(mm)	(mm)	(mm)	(mm)	(mm)	(mm)	(mm)	(kg)
3"	80	300	430	680	360	1280	2280	162
4"	100	300	600	680	360	1470	2580	195
6"	150	300	600	680	360	1470	2580	200
8"	200	300	780	740	780	1720	3080	295
10"	250	400	780	740	780	1720	3080	300
12"	300	400	990	740	780	2030	3630	335
12"L	300	450	1200	670	880	2340	4250	430
14"	350	400	990	740	780	2030	3630	360
14"L	350	450	1200	670	880	2340	4250	450
16"L	400	450	1200	670	880	2340	4250	465
18"L	450	600	1400	820	1160	2660	4750	635
20"L	500	600	1400	820	1160	2660	4750	665

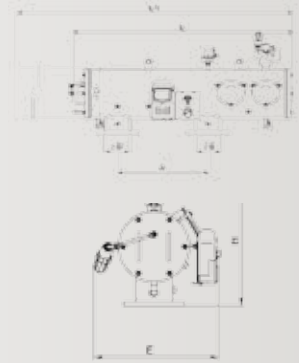

**F3200 – Product Head Loss Chart (bar) – 450–500 Parallel Long**

Size	Flow Rate (m <sup>3</sup> /h)												
	800	1000	1250	1500	1750	2000	2250	2500	2750	3000	3500	4000	4250
(inch)	Head Loss (bar)												
18 L	0,06	0,09	0,14	0,20	0,28	0,36	0,46	0,56	0,68	0,81	1,10	—	—
20 L	—	0,06	0,09	0,12	0,17	0,22	0,28	0,34	0,42	0,50	0,68	0,88	1,00

**F3200 (Angle) – Product Dimensions and Weights**

Size	B	D	A	E	H	T	Weight
(inch)	(mm)	(inch)	(mm)	(mm)	(mm)	(mm)	(kg)
2 Thread	50	250	196	540	570	185	27
3 Thread	80	250	260	540	750	195	41
3 Flange	80	250	280	540	770	220	41
4	100	250	280	540	905	220	48
4L							
6	150	300	540	600	1310	320	65
8	200	300	700	600	1530	320	78

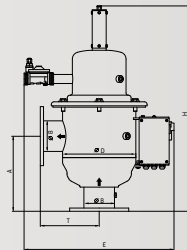

**F3200 – Product Head Loss Chart (bar) – 50–200 mm Angled**

Inlet/outlet		Flow Rate (m <sup>3</sup> /h)											
		15	25	50	75	100	150	200	250	300	350	400	500
(inch)	(mm)	Head Loss (bar)											
2	50	0,07	0,21	0,83	—	—	—	—	—	—	—	—	—
3	80	—	—	0,16	0,36	0,64	—	—	—	—	—	—	—
4	100	—	—	0,07	0,15	0,26	0,59	1,04	—	—	—	—	—
4L	100	—	—	0,05	0,11	0,19	0,43	0,76	—	—	—	—	—
6	150	—	—	—	—	0,06	0,13	0,23	0,35	0,51	0,69	0,90	—
8	200	—	—	—	—	—	0,04	0,08	0,12	0,17	0,23	0,30	0,47



*180 micron protective coating  
Sintered screen*

## F3300 Metal Screen Filter with Electric Operation

The F3300 Metal Screen Filters with Electric Operation are highly efficient and self-cleaning. The sintered screens are automatically cleaned with the continuous linear movement of the suction nozzles, which are driven by an electric motor. The flushing cycle of the F3300 Metal Screen Filters are actuated at a predetermined pressure differential or on a schedule using the timer. The filters continue to operate during flushing and utilize a small amount of water during flushing, making the filters very efficient.



### Product Information

Used as a primary filter for water containing large quantities of dirt

180 micron protective coating of extra durable polyester



### Product Options

Diameters: 2" (50 mm) – 20" (500mm)

Connections type: BSPT, BSTD and ISO-16

Screen options: 80, 100, 130, 200 micron

Body styles: parallel, parallel long



### Operating Guidelines

Minimum operating pressure: 1,0 bar

Maximum operating pressure: 8,0 bar

Maximum pressure: 10,0 bar

**F3300 Metal Screen Filter with Electric Operation – Product Specifications/Options**

Inlet/outlet		Body	Connections	Maximum Flow Rate	Flush Flow Rate Range	Screen Area	Screens	Current
(inch)	(mm)			(m <sup>3</sup> /h)	(m <sup>3</sup> /h)	(cm <sup>2</sup> )	(micron)	
2	50	Parallel	BSP, BSTD, ISO-16	25	11	2500	80, 100, 130, 200	AC 1x220V 50Hz, AC 1x110V 60Hz
3	80	Parallel	BSTD, ISO-16	40	11	2500	80, 100, 130, 200	AC 1x220V 50Hz, AC 1x110V 60Hz
4	100	Parallel	BSTD, ISO-16	60	11	2500	80, 100, 130, 200	AC 1x220V 50Hz, AC 1x110V 60Hz
4L	100	Parallel	BSTD, ISO-16	80	16	4000	80, 100, 130, 200	AC 1x220V 50Hz, AC 1x110V 60Hz
6	150	Parallel	BSTD, ISO-16	120	16	4000	80, 100, 130, 200	AC 1x220V 50Hz, AC 1x110V 60Hz
6L	150	Parallel	BSTD, ISO-16	150	16	6000	80, 100, 130, 200	AC 1x220V 50Hz, AC 1x110V 60Hz
8	200	Parallel	BSTD, ISO-16	200	16	6000	80, 100, 130, 200	AC 1x220V 50Hz, AC 1x110V 60Hz
8L	200	Parallel	BSTD, ISO-16	300	28	8000	80, 100, 130, 200	AC 1x220V 50Hz, AC 1x110V 60Hz
10	250	Parallel	BSTD, ISO-16	300	22	6000	80, 100, 130, 200	AC 1x220V 50Hz, AC 1x110V 60Hz
10L	250	Parallel	BSTD, ISO-16	400	28	8000	80, 100, 130, 200	AC 1x220V 50Hz, AC 1x110V 60Hz
12	300	Parallel	BSTD, ISO-16	470	28	8000	80, 100, 130, 200	AC 1x220V 50Hz, AC 1x110V 60Hz
12L	300	Parallel Long	BSTD, ISO-16	600	23	10050	80, 100, 130, 200	AC 1x220V 50Hz, AC 1x110V 60Hz
14	350	Parallel	BSTD, ISO-16	550	28	8000	80, 100, 130, 200	AC 1x220V 50Hz, AC 1x110V 60Hz
14L	350	Parallel Long	BSTD, ISO-16	800	23	10050	80, 100, 130, 200	AC 1x220V 50Hz, AC 1x110V 60Hz
16L	400	Parallel Long	BSTD, ISO-16	1,000	23	10050	80, 100, 130, 200	AC 1x220V 50Hz, AC 1x110V 60Hz
18L	450	Parallel Long	BSTD, ISO-16	1,300	23	16150	80, 100, 130, 200	AC 1x220V 50Hz, AC 1x110V 60Hz
20L	500	Parallel Long	BSTD, ISO-16	1,600	23	16150	80, 100, 130, 200	AC 1x220V 50Hz, AC 1x110V 60Hz

**F3300 (Parallel) – Product Dimensions and Weights**

In/Out	B	D	A	E	H	L	L1	Weight
(inch)	(mm)	(inch)	(mm)	(mm)	(mm)	(mm)	(mm)	(kg)
2	50	12	430	680	650	1480	2480	175
3	80	12	430	680	650	1480	2480	178
4	100	12	600	680	650	1660	2780	212
6	150	12	600	680	650	1660	2780	215
8	200	12	780	715	780	1925	3280	312
10	250	16	780	715	780	1925	3280	318
12	300	16	990	715	780	2225	3830	350
14	350	16	990	715	780	2225	3830	376

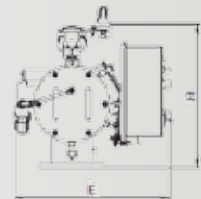

**F3300 (Parallel) – Product Dimensions and Weights**

In/Out	B	D	A	E	H	L	L1	Weight
(inch)	(mm)	(inch)	(mm)	(mm)	(mm)	(mm)	(mm)	(kg)
12 L	300	18	1200	700	890	2820	4710	450
14 L	350	18	1200	735	890	2820	4710	465
16 L	400	18	1200	760	890	2820	4710	480
18 L	450	24	1400	860	1140	3110	5210	650
20 L	500	24	1400	985	1140	3110	5210	679



### F3300 Metal Screen Filter with Electric Operation – Product Head Loss chart (bar) – 50–150 mm parallel

Filter Inlet/Outlet (inch)	Flow Rate (m <sup>3</sup> /hr)												
	15	20	25	50	75	100	125	150	200	250	300	350	400
2	0,09	0,16	0,25	1,00	—	—	—	—	—	—	—	—	—
3	—	—	0,05	0,21	0,46	0,83	—	—	—	—	—	—	—
4	—	—	—	0,07	0,16	0,28	0,44	0,64	1,13	—	—	—	—
6	—	—	—	—	—	0,06	0,09	0,12	0,22	0,35	0,50	0,68	0,89

### Product Head Loss Chart (bar) – 200–350 mm Parallel

Filter Inlet/Outlet (inch)	Flow Rate m <sup>3</sup> /hr													
	200	300	400	500	600	700	800	900	1000	1200	1500	1800	2000	
8	0,08	0,17	0,3	0,47	0,68	0,92	1,2	—	—	—	—	—	—	
10	—	0,07	0,13	0,21	0,3	0,4	0,53	0,67	0,83	1,19	—	—	—	
12	—	—	0,07	0,11	0,15	0,21	0,27	0,34	0,42	0,61	0,95	—	—	
14	—	—	—	0,06	0,09	0,12	0,15	0,19	0,24	0,35	0,54	0,78	0,96	

### Product Head Loss Chart (bar) – 300 – 400 mm Parallel Long

Filter (inch)	Flow Rate (m <sup>3</sup> /hr)													
	400	500	600	700	800	900	1000	1200	1500	1800	2000	2300	2500	
12 L	0,07	0,11	0,15	0,21	0,27	0,34	0,42	0,61	0,95	—	—	—	—	
14 L	—	0,06	0,09	0,12	0,15	0,19	0,24	0,35	0,54	0,78	0,96	—	—	
16 L	—	—	0,05	0,07	0,09	0,12	0,15	0,21	0,33	0,48	0,59	0,78	0,92	

### Product Head Loss Chart (bar) – 450 – 500 mm Parallel Long

Filter (inch)	Flow Rate (m <sup>3</sup> /hr)												
	800	1000	1250	1500	1750	2000	2250	2500	2750	3000	3500	4000	4250
18 L	0,06	0,09	0,14	0,20	0,28	0,36	0,46	0,56	0,68	0,81	1,10	—	—
20 L	—	0,06	0,09	0,12	0,17	0,22	0,28	0,34	0,42	0,50	0,68	0,88	1,00



*180 micron protective coating  
Sintered screen*

## F3300 Metal Screen Filter with Brushes, Electric Operation (Automatic)

F3300 Metal Screen Filters with Brushes and Electric Operation (Automatic) are the ideal choice for applications with coarse dirt. This line of F3300 Metal Screen Filters utilize a brush assembly cleaning mechanism and are electrically operated, self cleaning filters. The filter's operation is controlled by a simple flush controller and the cleaning process is activated automatically. The cleaning process can also be activated manually.



### Product Information

Applications with Coarse dirt.  
Brush assembly cleaning mechanism  
Cleaning process is activated automatically  
Designed for emission degres with large openings such as sprinklers



### Product Options

Diameters: 3" (80 mm) - 10" (250 mm)  
Connections type: BSPT, BSTD and ISO-16  
Screen options: 200, 400 micron  
Body styles: parallel  
Other screen with higher micron on request



### Operating Guidelines

Minimum operating pressure: 1,0 bar  
Maximum operating pressure: 8,0 bar  
Maximum pressure: 10,0 bar

### F3300 Metal Screen Filter with Brushes, Electric Operation (Automatic)– Product specifications/options

Inlet/outlet		Body	Connections	Max. Flow Rate	Screen Area	Screens	Current Options
(inch)	(mm)			(m <sup>3</sup> /h)	(cm <sup>2</sup> )	(micron)	
4	100	Parallel	BSTD, ISO-16	80	3500	200, 400	AC 3x400-480V 50/60Hz, AC 3X220V 60Hz
6	150	Parallel	BSTD, ISO-16	160	5000	200, 400	AC 3x400-480V 50/60Hz, AC 3X220V 60Hz
8	200	Parallel	BSTD, ISO-16	300	6000	200, 400	AC 3x400-480V 50/60Hz, AC 3X220V 60Hz
10	250	Parallel	BSTD, ISO-16	500	7500	200, 400	AC 3x400-480V 50/60Hz, AC 3X220V 60Hz
12	300	Parallel	BSTD, ISO-16	650	10400	200, 400	AC 3x400-480V 50/60Hz, AC 3X220V 60Hz
14	350	Parallel	BSTD, ISO-16	1000	10400	200, 400	AC 3x400-480V 50/60Hz, AC 3X220V 60Hz

For other screen options ask Rivulis representative

### Product Head Loss Chart (bar) – 100 – 200 mm Parallel

Size (Inlet/Outlet)	Flow Rate (m <sup>3</sup> /hr)												
	50	75	100	125	150	175	200	250	300	350	400	500	600
(inch)	Head Loss (bar)												
4	0,05	0,11	0,2	0,31	0,45	0,61	0,8	1,25	–	–	–	–	–
6	–	–	0,06	0,09	0,13	0,18	0,23	0,36	0,52	0,71	0,93	–	–
8	–	–	–	–	0,05	0,07	0,09	0,15	0,21	0,29	0,38	0,59	0,85

### Product Head Loss Chart (bar) – 250 – 350 mm Parallel

Size (Inlet/Outlet)	Flow Rate (m <sup>3</sup> /hr)													
	300	400	500	600	700	800	900	1000	1200	1400	1600	1800	2000	
(inch)	Head Loss (bar)													
10	0,07	0,13	0,2	0,29	0,39	0,51	0,56	0,8	1,15	–	–	–	–	
12	0,04	0,07	0,11	0,16	0,22	0,29	0,37	0,45	0,65	0,89	1,16	–	–	
14	–	–	0,06	0,08	0,11	0,15	0,19	0,23	0,33	0,45	0,59	0,75	0,93	

**F3300 (Parallel) – Dimensions and Weights - 2-8"**

Size (Inlet/Outlet)	B	D	A	H	L	L1	Weight
(inch)	(mm)	(inch)	(mm)	(mm)	(mm)	(mm)	(kg)
4	100	12	600	650	1180	1650	95
6	150	12	600	655	1425	2145	114
8	200	12	780	690	1605	2455	128

**F3300 (Parallel) – Dimensions and Weights - 10-14"**

Size (Inlet/Outlet)	B	D	A	E	H	L	L1	Weight
(inch)	(mm)	(mm)	(mm)	(mm)	(mm)	(mm)	(mm)	(kg)
10	250	400	900	700	1100	2000	3100	266
12	300	450	1000	800	1200	2200	3300	280
14	350	450	1000	800	1200	2200	3300	300

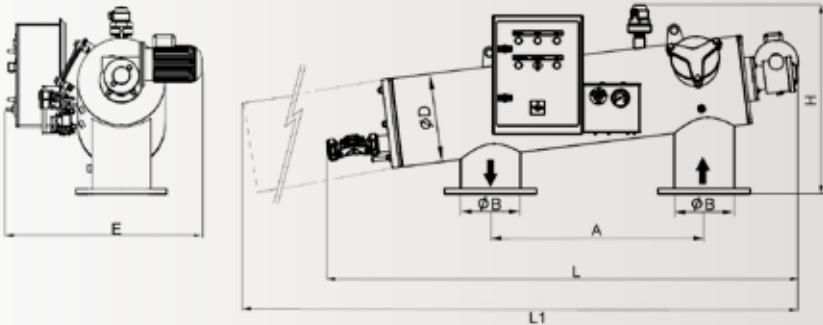

Free space required for maintenance



*Minimum 180 micron  
protective coating*

## F3400 Metal Screen Filter with Continuous Circulation

F3400 Metal Screen Filters with Continuous Circulation are the ideal choice for applications without electricity. The F3400 Filters utilizes centrifugal movement of the water to keep the screen clean during the irrigation process. The sediments collect in the lower chamber to be purged by the control valve. As a result there is no increase in head loss during operation. The flushing of the collecting chamber is done manually or automatically by a flushing controller by timing during the irrigation process.



### Product Information

Equipped with a manual cleaning mechanism. The filter is best suited for applications without a power supply.

The filters come with a mechanical differential pressure indicator which indicates filter build up



### Product Options

Diameters: 3" (80 mm) - 10" (250 mm)

Connections type: BSTD, ISO-16

Screen options: 80, 100, 130, 200 micron

Body styles: parallel



### Operating Guidelines

Minimum operating pressure: 2,0 bar

Maximum operating pressure: 8,0 bar

Maximum pressure: 10,0 bar

Recommended head loss 0,25-0,6 bar

**F3400 Metal Screen Filter with Continuous Circulation – Product specifications / Options**

Inlet/outlet		Body	Connections	Flow Rate (m³/h)	Screens (micron)	Control
(inch)	(mm)					
3	80	In-Line	BSTD, ISO-16	25-45	80, 100, 130, 200	DC, Manual
4	100	In-Line	BSTD, ISO-16	40-75	80, 100, 130, 200	DC, Manual
6	150	In-Line	BSTD, ISO-16	80-150	80, 100, 130, 200	DC, Manual
8	200	In-Line	BSTD, ISO-16	165-300	80, 100, 130, 200	DC, Manual
10	250	In-Line	BSTD, ISO-16	270-500	80, 100, 130, 200	DC, Manual

**Flow Rate Based On Head Loss Chart – 4 Open Holes**

Size (Inlet/Outlet)		Head Loss (bar)					
		0,25	0,30	0,40	0,50	0,60	0,70
(inch)	(mm)	Flow Rate Q (m³/h)					
3	80	32	35	40	45	49	53
4	100	53	58	67	75	82	89
6	150	106	116	134	150	164	177
8	200	210	230	270	300	330	355
10	250	355	390	450	500	550	590

**Flow Rate Based on Head Loss Chart – 3 Open Holes (1 Stopper)**

Size (Inlet/Outlet)		Head Loss (bar)					
		0,25	0,30	0,40	0,50	0,60	0,70
(inch)	(mm)	Flow Rate Q (m³/h)					
3	80	25	27	31	35	38	41
4	100	41	45	52	58	64	69
6	150	81	89	103	115	126	136
8	200	165	180	205	230	255	275
10	250	270	295	345	385	420	455

**F3400 (Continuous) – Product Dimensions and Weights**

Size (Inlet/Outlet)		B	D	A	H	Weight
(inch)	(mm)	(mm)	(inch)	(mm)	(mm)	(kg)
3	80	80	8	525	720	29
4	100	100	8	565	900	35
6	150	150	10	735	1200	56
8	200	200	16	875	1050	130
10	250	250	16	1,195	1100	175

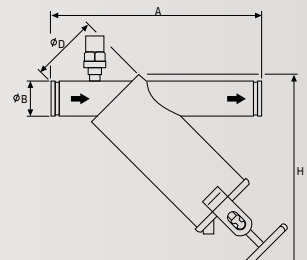



## F3400 Metal Screen Filter with Flushing Mechanism

The F3400 Metal Screen Filters with Internal flushing Mechanism (Semi-Automatic) are equipped with a manual cleaning mechanism. The filter is best suited for applications without a power supply. The F3400 Metal Screen Filter with Internal Flushing mechanism easy to operate and maintain. The filters come with a mechanical differential pressure indicator which indicates filter build up.



### Product Information

Equipped with a manual cleaning mechanism  
 The filter is best suited for applications without a power supply  
 The filters come with a mechanical differential pressure indicator which indicates filter build up



### Product Options

Diameters: 4" (100 mm) – 8" (200 mm)  
 Connections type: BSTD, ISO-16  
 Screen options: 130, 200 micron  
 Body styles: parallel



### Operating Guidelines

Minimum operating pressure: 2,0 bar  
 Maximum operating pressure: 8,0 bar  
 Maximum pressure: 10,0 bar

**F3400 Metal Screen Filter with Flushing Mechanism – Product Specifications/ Options**

Inlet/outlet		Body	Connections	Maximum Flow Rate	Screen Area	Screens
(inch)	(mm)					
3	80	In-Line / Angled	BSTD, ISO-16	50	1000	200 ,130 ,100
4	100	In-Line / Angled	BSTD, ISO-16	80	2150	200 ,130 ,100
4	100	Parallel	BSTD, ISO-16	80	2500	200 ,130 ,100
6	150	Parallel	BSTD, ISO-16	150	5000	200 ,130 ,100
8	200	Parallel	BSTD, ISO-16	250	5000	200 ,130 ,100

**Head Loss Chart (bar)**

Filter Size		Flow Rate (m <sup>3</sup> /h)												
		50	75	100	125	150	175	200	250	300	350	400	500	600
(inch)	(mm)	Head Loss (bar)												
4	100	0,05	0,11	0,20	0,31	0,45	0,61	0,80	1,25					
6	150			0,06	0,09	0,13	0,18	0,23	0,36	0,52	0,71	0,93		
8	200					0,05	0,07	0,09	0,15	0,21	0,29	0,38	0,59	0,85

**F3400 (Flushing Mechanism) – Dimensions and Weights**

Size	B	D	A	H	L	L1	Weight
(inch)	(mm)	(inch)	(mm)	(mm)	(mm)	(mm)	(kg)
4	100	12	400	570	890	1410	86
6	150	12	780	570	1380	2300	106
8	200	12	780	610	1380	2300	107

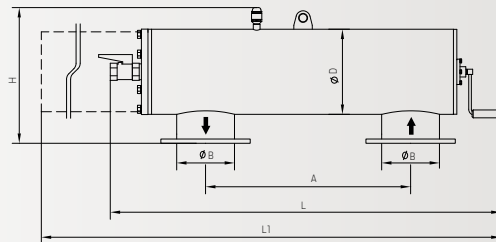



*180 micron protective coating  
Sintered screen*

## F3400 Metal Screen Filter with Internal Flushing Mechanism and Brushes

F3400 Metal Screen Filter with Internal Flushing mechanism and Brushes is manually operated and an efficient solution for locations without power supply. These models of F3400 Metal Screen Filters are equipped with a pressure gauge and a 3-way valve for easy check of head-loss. This stainless still 316 screen filter contains a manually operated brush assembly for efficient cleaning of the screen and used for sites with low pressure.



### Product Information

Efficient cleaning of the screen and used for sites with low pressure

Manually operated

Efficient solution for locations without power supply

Equipped with a pressure gauge and a 3-way valve for easy check of head-loss



### Product Options

Diameters: 3" (80 mm) - 10" (250 mm)

Connections type: BSTD, ISO-16

Screen options: 200, 400 micron

Body styles: In-Line, parallel



### Operating Guidelines

Minimum pressure: 1,0 bar

Maximum operating pressure: 8,0 bar

Maximum pressure: 10,0 bar

**F3400 Metal Screen Filter with Internal Flushing mechanism and Brushes – Product Specifications/Options**

Inlet/outlet		Body	Connections	Maximum Flow Rate	Screen Area	Screens
(inch)	(mm)					
3	80	In-Line	BSTD, ISO-16	50	1500	400 ,200
4	100	In-Line	BSTD, ISO-16	80	2200	400 ,200
4	100	Parallel	BSTD, ISO-16	80	3500	400 ,200
6	150	Parallel	BSTD, ISO-16	160	5000	400 ,200
8	200	Parallel	BSTD, ISO-16	300	6000	400 ,200

**F3400 Metal Screen Filter Head Loss Chart (bar)**

Inlet/Outlet		Flow Rate (m <sup>3</sup> /h)												
		50	75	100	125	150	175	200	250	300	350	400	500	600
(inch)	(mm)	Head Loss (bar)												
(In-Line)														
3	80	0,17	–	0,66	–	–	–	–	–	–	–	–	–	–
4	100	0,05	–	0,21	–	–	–	0,83	–	–	–	–	–	–
(Parallel)														
4	100	0,05	0,11	0,2	0,31	0,45	0,61	0,80	1,25	–	–	–	–	–
6	150	–	–	0,06	0,09	0,13	0,18	0,23	0,36	0,52	0,71	0,93	–	–
8"	200	–	–	–	–	0,05	0,07	0,09	0,15	0,21	0,29	0,38	0,59	0,85

**F3400 (In-Line) Dimensions and Weights**

Size	B	D	A	H	Weight
(inch)	(mm)	(inch)	(mm)	(mm)	(kg)
3	80	6	555	590	20
4	100	8	565	755	34

**F3400 (Parallel) Dimensions and Weights**

Size	B	D	A	H	L	L1	Weight
(inch)	(mm)	(inch)	(mm)	(mm)	(mm)	(mm)	(kg)
4	100	12	600	650	1180	1650	95
6	150	12	600	655	1425	2145	114
8	200	12	780	690	1605	2455	128

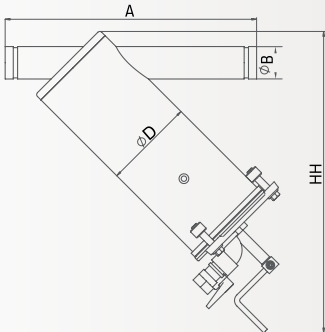

Free space required for maintenance



*Screens are designed with a molded plastic rib cage.*

## F6100 Plastic Screen Filter

The F6100 Plastic Screen Filter features a large filtration screen that increases the flow rate capacity and extends the time between flushing. The F6100 Plastic Screen Filters are used as primary filters in small irrigation systems and as back-up filters in field zone applications. The screen of the F6100 Plastic Screen Filter has a molded plastic rib cage for superior strength and depending on size it is outfitted with either a twin layer stainless steel weave-wire or polyamide screen. Both the design and materials used in the F6100 allow for easy maintenance and years of high performance.



### Product Information

The F6100 Plastic Screen Filters are used as primary filters in small irrigation systems and as back-up filters in field zone applications

The filters can be ordered with threaded or Grooved connections and with one or two inlets



### Product Options

Diameters: 3/4" – 3"

Connections type: BSP, VIC

Screen options: 100, 130, 200 micron

Body styles: In-Line, Angled



### Operating Guidelines

Maximum operating pressure: 8,0 bar (available only in 2" and 3" filters), 10,0 bar

**F6100 Plastic Screen Filter – Product Specifications/Options**

Inlet/outlet		Body	Connections	Maximum Flow Rate	Screen Area	Screens	Screen Type	Operating Pressure
(inch)	(mm)							
0,75	20	In-Line	BSP	5	73	100, 130	Polyamide	10
1,0	25	In-Line	BSP	6	113	100, 130, 200	Polyamide	10
1,5	40	In-Line	BSP	10	291	100, 130, 200	Polyamide	10
2,0	50	In-Line/Angled	BSP	30, 40	556	100, 130, 200	Stainless steel	8
2,0	50	In-Line/Angled	BSP	30, 40	770	100, 130, 200	Stainless steel	10
2,0 Long	50	In-Line/Angled	BSP	48	1150	100, 130, 200	Stainless steel	10
3,0	80	In-Line/Angled	BSP	60	1150	100, 130, 200	Stainless steel	10

**Screen Filter  
2" – 130 micron**

Flow Rate (m <sup>3</sup> /h)	Head Loss (bar)
11	0,03
16	0,07
24	0,14
30	0,24
36	0,34
40	0,43

**Screen Filter  
2" L – 130 micron**

Flow Rate (m <sup>3</sup> /h)	Head Loss (bar)
12	0,03
18	0,06
24	0,11
30	0,17
36	0,25
42	0,34
48	0,44

**Screen Filter  
3" – 130 micron**

Flow Rate (m <sup>3</sup> /h)	Head Loss (bar)
15	0,02
24	0,04
29	0,05
36	0,09
40	0,11
53	0,19
57	0,22

**F6100 – Dimensions**

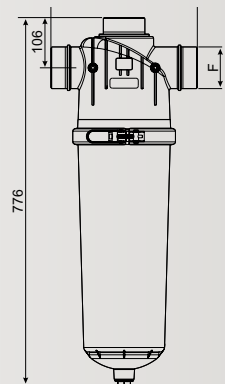
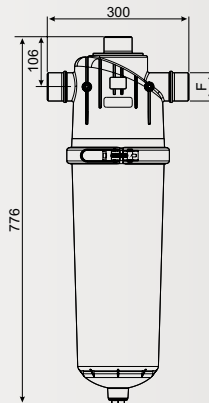
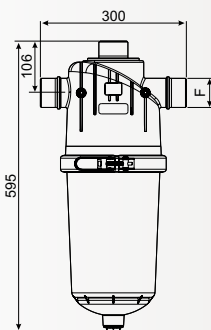



*Semi-Automatic Screen Filter with clogging indicator*

## F6400 Plastic Screen Filter (Semi-Automatic)

The F6400 Plastic Screen Filter is an ideal choice as a primary filter in a small irrigation system or as a back-up field zone filter. The F6400 Plastic Screen Filter has several key features including a large stainless steel screen, a pressure differential sensor (clogging indicator), a stainless steel clamp and a simple to operate flushing mechanism. The large pressure differential sensor provides the user the ability to easily view the level of clogging or the pressure differential across the screen. The large 316 stainless steel screen reduces maintenance and provides longer service times before flushing intervals.



### Product Information

The F6400 Plastic Screen Filters are used as primary filters in small irrigation systems and as back-up filters in field zone applications



### Product Options

Diameters: 2" – 3"

Connections type: BSP

Screen options: 100, 130, 200 micron

Body styles: In-Line



### Operating Guidelines

Maximum operating pressure: 10,0 bar

**F6400 Plastic Screen Filter (Semi-Automatic) – Product Specifications/Options**

Diameter	Body type	Connectors	Max. Flow rate	Screen area	Screen choices	Screen type
(inch)			(m <sup>3</sup> /h)	(cm <sup>2</sup> )	(micron)	
2	In-Line	BSP, NPT	25	554	100, 130, 200	Stainless steel (316 woven wire)
3	In-Line	BSP, NPT	40	831	100, 130, 200	Stainless steel (316 woven wire)

**Head loss (bar)/Flow Rate (m<sup>3</sup>/h) - 2"**

Flow Rate (m <sup>3</sup> /h)	Head Loss (bar)		
	200 Micron	130 Micron	100 Micron
10	0	0,04	0,06
15	0,02	0,09	0,12
20	0,05	0,14	0,17
25	0,09	0,20	0,23
30	0,14	0,26	0,29
35	0,21	0,32	0,36
40	0,28	0,39	0,44

**Head loss (bar)/Flow Rate (m<sup>3</sup>/h) - 3"**

Flow Rate (m <sup>3</sup> /h)	Head Loss (bar)		
	200 Micron	130 Micron	100 Micron
20	0	0,02	0,04
25	0,02	0,04	0,07
30	0,05	0,08	0,11
35	0,09	0,14	0,17
40	0,14	0,21	0,25
45	0,19	0,28	0,33
50	0,24	0,35	0,40

**F6400 – Dimensions**

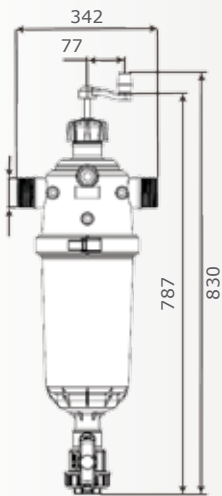

2" Filter

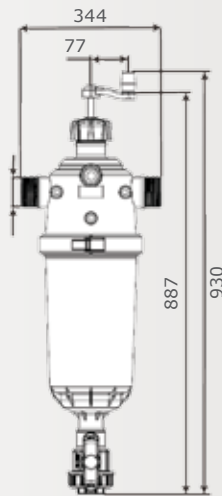

3" Filter



Reinforced nylon body

## F7000 Plastic Disc Filter

The F7000 Plastic Disc Filter is used as a primary filter for small irrigation systems and as a back-up filter for field zones. This filter can stop or retain large amount of solids from the water due to the depth feature of the disc element and the size of element. In addition, the filters utilize a flow deflecting plate that circulates water inside the filter and forces particles away from the disc elements and down to the bottom of the filter ready to be flushed out. All of these features contribute to improved filter efficiency and increased time between flushing.



### Product Information

Primary filter for small irrigation systems and as a back-up filter for field zones

Retains large amount of solids from the water due to the depth feature of the disc element and the size of element  
All of the F7000 Disc Filters feature a flow deflecting plate that circulates water inside the filter and forces particles away from the disc elements

The F7000 Disc Filters are highly efficient filters, which decrease the frequency of flushings

Easy to maintain and operate for years



### Product Options

Diameters: 1" (25 mm) – 3" (80 mm)

Connections type: BSP, VIC

Screen options: 100, 130, 200 micron

Body styles: In-Line, Angled



### Operating Guidelines

Maximum operating pressure: 8 bar (1½ and 2" models), 10 bar (1", 1.5", 2", 2"L, 3" models)

**F7000 Plastic Disc Filter – Product Specifications/Options**

Diameter (inch)	Body	Connector	Maximum Flow Rate (m <sup>3</sup> /h)	Filtration Area (cm <sup>2</sup> )	Disc (micron)
1,0	In-line	BSP	6	204	130
1½	In-line	BSP	10	281	130
2,0	In-line/Angled	BSP	30	1,360	100, 130, 200
2,0 Long	In-line/Angled	BSP, VIC	40	2,090	100, 130, 200
3,0	In-line/Angled	BSP, VIC	50	2,090	100, 130, 200

Note: VIC is available with in-line option only

**Screen Filter  
2" – 130 micron**

Flow Rate (m <sup>3</sup> /h)	Head Loss (bar)
12	0,06
18	0,14
25	0,24
31	0,38
34	0,43
37	0,50
40	0,55

**Screen Filter  
2" L – 130 micron**

Flow Rate (m <sup>3</sup> /h)	Head Loss (bar)
12	0,05
18	0,10
24	0,17
30	0,24
36	0,31
42	0,40
48	0,51

**Screen Filter  
3" – 130 micron**

Flow Rate (m <sup>3</sup> /h)	Head Loss (bar)
12	0,03
19	0,05
24	0,08
33	0,16
40	0,22
47	0,31
55	0,43

**F7000 Plastic Disc Filter – Dimensions**

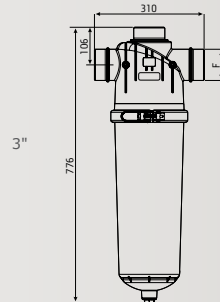
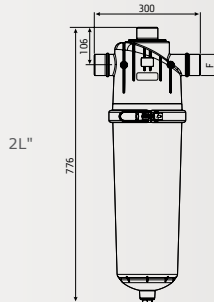
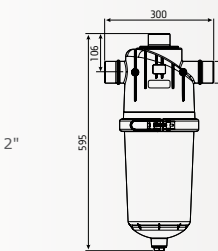



*Epoxy coating optional*

## F9000 Gravity Filter



### Product Information

F9000 Gravity Filter is the ideal choice for low energy drip systems. F9000 Gravity Filters are continuous self-cleaning gravity filters and are specifically designed to deal with high load of suspended solids. The filtering method is based on gravity flow through a stainless steel screen. The filter is designed to continuously remove dirt from screen during filtration process without interruption to filtered water supply. The efficient self cleaning process combines rotating cleaning jets assembly which blows away the dirt from the screen and into raw water flow that sweeps the dirt from the screen surface to the dirt collection cell.



### Product Options

Connection diameters: 6", 8"

Body diameters: 48", 60"

Connection types: BSTD, ISO-16

Screen options: 100, 130, 200 micron



### Operating Guidelines

Minimum pressured required for jet system: 1,0 bar

Minimum flow rate for water jet flushing system: 1 m<sup>3</sup>/h

**F9000 Gravity Filter – Product Specifications/Options**

Size Connection		Body Diameter		Connections	Maximum Flow Rate (m <sup>3</sup> /h)	Screens (micron)	Current Options
(inch)	(mm)	(inch)	(mm)				
6	150	48	1220	BSTD, ISO-16	100	100, 130, 200	DC -12V
8	200	60	1524	BSTD, ISO-16	170	100, 130, 200	DC -12V

**F9000 – Product Dimensions**

Body	B	D	H1	H2	H	Weight
(inch)	(mm)	(mm)	(mm)	(mm)	(mm)	(kg)
48	150	1200	645	1663	1950	450
60	200	1500	645	1663	1950	500

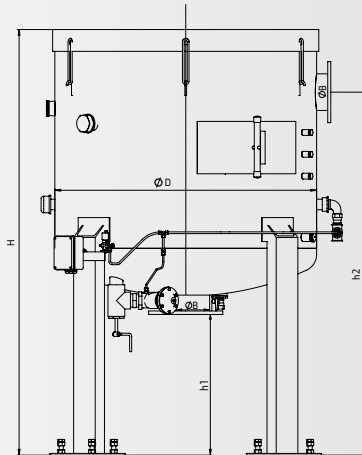



*Strong yarn structure to reduce rotation and elongation.*

## Pro-Flat Layflat

Durable hose, made of premium resins to withstand tough conditions.



### Product Information

Thick wall dimensions and strong yarn structure help product to hold connections and resist bursting. Pro-Flat is made with premium resins which allow the product to withstand the tough conditions endured in the agricultural and the mining industries.

The layflat is made with thick wall dimensions and the strong yarn structure help the product to hold connections and resist bursting.

The design of Pro-Flat reduces the amount of rotation and elongation each time the system is pressurized.

Applications include transfer lines, sub-main lines, and discharge lines.



### Product Options

Color: Green

Diameters – 40 to 250 mm



### Operating Guidelines

Maximum operating pressures – 2,4 to 6,2 bar (pressure is related to diameter of the hose)

**Pro-Flat Layflat – Product Specifications/Options**

Inside Diameter	Outside Diameter	Wall Thickness	Maximum Operating Pressure	Reel Length	Reel Weight	Item Number
(mm)	(mm)	(mm)	(bar)	(m)	(kg)	
40	43	1,5	6,2	91,4	21	101000377
53	56	1,6	5,5	91,4	29	101000378
78	81	1,7	4,8	91,4	50	101000379
103	107	1,91	4,8	91,4	60	101000380
155	159	2,11	3,4	91,4	115	101000382
205	210	2,29	3,1	91,4	198	101000383
252	266	2,49	2,4	30,5	90	101000384



Options: Standard Pressure  
(Blue) and High pressure  
(Red)

## T-Tape Layflat PVC Hose

T-Tape Layflat PVC Hose is an excellent choice as supply manifolds or transfer lines in drip irrigation systems. Each of the T-Tape Layflat PVC Hoses are manufactured using advanced technology. The manufacturing technology used produces a high quality product with homogeneous construction, all in one continuous process. The result is increased longitudinal strength and the elimination of separations between the layers. And as an additional benefit, the smooth inside layer reduces friction, creating lower pressure loss in the irrigation system.



### Product Information

Three-layer layflat hose: Outer layer provides durability and protection against aging and weathering  
Middle layer provides strength and flexibility while reducing elongation  
Smooth internal layer reduces friction and allows lower pressure loss



### Product Options

Standard Pressure (Blue) – Diameters – 40 to 200 mm  
High Pressure (Red) – Diameters – 50 to 150 mm



### Operating Guidelines

Standard Pressure (Blue)  
Operating pressure – 2,9 to 4,9 bar  
High Pressure (Red)  
Operating pressure – 6,8 to 10,3 bar  
(pressure is related to diameter of the hose)

**T-Tape Layflat PVC Hose – Product Specifications/Options**

Product	Color	Nominal Size		Color	Inside Diameter	Wall Thickness	Maximum Operating Pressure	Reel Length	Reel Weight	Item Number
		(inch)	(mm)							
Standard	Blue	1,5	40	Blue	42,5	1,25	4,9	100	21	101001068
		2	50	Blue	55	1,30	4,4	100	29	101001070
		3	80	Blue	79,5	1,70	3,9	100	56	101001073
		4	100	Blue	105	1,75	3,9	100	72	101001075
		6	150	Blue	157	1,95	2,9	100	120	101001078
		8	200	Blue	207	2,20	2,9	100	183	101001982
High	Red	2	50	Red	52,5	2,05	10,3	100	42	101001069
		3	75	Red	78,5	2,25	8,8	100	66	101001072
		4	100	Red	104	2,55	8,8	100	100	101001074
		6	150	Red	155	2,95	6,8	100	168	101001077



## Rivulis Air Valves

The Rivulis line of air valves include an Air & Vacuum Release Valve, a Continuous Air Valve, and a Combination Air Valve. The air valves are recommended protection for drip and micro irrigation systems, helping to maintain proper hydraulic dynamics in the system design. Each type of air valve is designed for a specific function. The Rivulis Air and Vacuum Release Valve is designed to allow large volumes of air to exit on during start up and enter during shut down of an irrigation system. The Rivulis Continuous Air Valve allows small amounts of trapped air in a pipeline under pressure to be released. The combination air valve does both applications.



### Product Information

Premium resins  
 Long lasting performance  
 Three types of valves: Air & Vacuum, Continuous and Combination



### Product Options

Size: 1/2" to 3"  
 Thread: male or female



### Operating Guidelines

Minimum operating pressure: 0,10 bar  
 Maximum pressure: 10,0 bar (Air & Vacuum)  
 Maximum operating temperature: 60° C  
 Air Valves – Product specifications/options

**Rivulis Air Valves – Product Specifications/Options**

Product Description	Connection Size	Minimum Operating Pressure	Maximum Operating Pressure	Thread Type	Connections	Ordering Unit	Item Number
	(inch)	(bar)	(bar)				
Air Valve and Vacuum Release Valve	3/4	0,01	10	Male	BSP	24	101045527
	1	0,01	10	Male	BSP	24	101045529
	2	0,01	10	Female	BSP	12	101045531
	3	0,01	10	Female	BSP	6	101045533
Continuous Air Valve	1/2	0,1	10	Male	BSP	6	WT12508
	3/4	0,1	10	Male	BSP	6	WT12510
	1	0,1	10	Male	BSP	6	WT12512
Combination Air Valve	1/2	0,1	10	Male	BSP	6	WT12514
	3/4	0,1	10	Male	BSP	6	WT12516
	1	0,1	10	Male	BSP	6	WT12518
	2	0,1	10	Female	BSP	6	WT12520

### Air & Vacuum Release Valve – 3/4", 1", 2", 3" Models

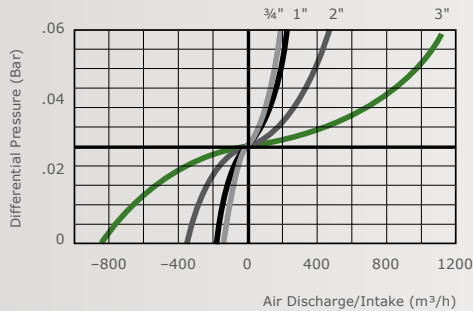

### Continuous Air Valve – 1/2", 3/4", 1" Models

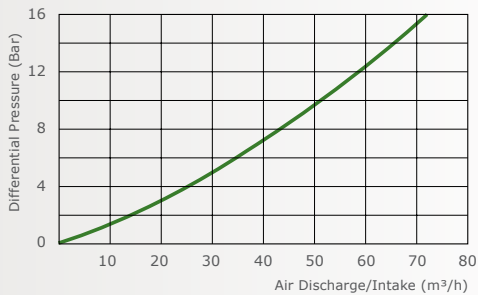

### Combination Air Valve – 1/2", 3/4", 1" Models

Continuous Air Valve Air Discharge

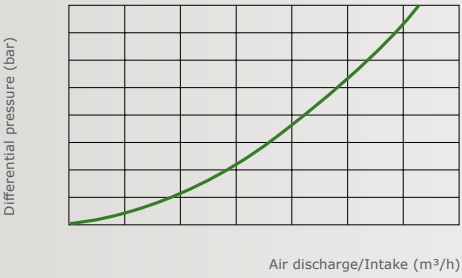

### Combination Air Valve – 2" Models

Continuous Air Valve Air Discharge

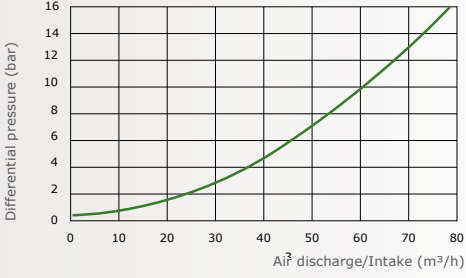

Air & Vacuum Release Air Discharge

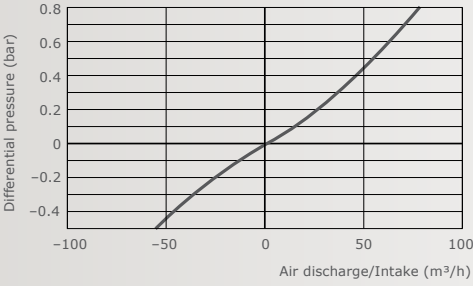

Air & Vacuum Release Air Discharge

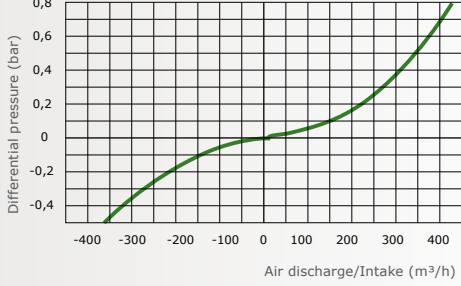

## V1000 Hydraulic Control Valve



*Glass-filled Nylon Construction*

The V1000 Hydraulic Control Valves are the economical choice for residential, commercial, and small agricultural irrigation systems. The V1000 Hydraulic Control Valve can be used to control blocks with flows up to 25 cubic meters per hours. All the V1000 Control Valves are designed with a manual throttling knob to provide extra flexibility to control pressure and flow. The V1000 Control Valve body cover and diaphragm piston assembly are constructed of glass-filled nylon to meet rough conditions. The valve body design includes a full-bore seat with unobstructed flow path, providing low head loss in high flow conditions. The electric valve control circuit is internal (2-way circuit) providing some significant benefits such as no external tubes or accessories.



### Product Information

Manual/Electric

Manual throttling

Glass-filled nylon construction

Full bore seat

2-Way internal or 3-Way external



### Product Options

Valve Models: On/Off Manual, On/ Off Electric, Pressure Reducing Manual. Pressure Reducing Electric

Actuation: Manual / Electric Sizes:

In-Line: 1", 1½", 2", Angled: 2"

PR/PS – 4,0/2,0 bar, QR – 6,0 bar

2-Way Internal or 3-Way External Controls

End Connectors : Threaded (BSP)



### Operating Guidelines

Operating Pressure Range: 0,5–10 bar

Maximum Pressure Rating: 10 bar

Pre-set pressure: 3-way–2,5 bar

(can be adjust 0,8-6,5 bar)

### V1000 Hydraulic Control Valves – Configuration Options

Actuation	Options	Pre-Set Pressure (bar)	On-Off		Pressure Reducing	
			Manual	Electric	Manual	Electric
Control Circuit / Pilot	No Pilot		V	V		
	0,8–6,5 bar, 3-Way	2,5			V	V
Solenoid	9 Volt DC – Latch			V		
	12 Volt DC – Latch					V
	24 Volt AC – Normally Closed			V		V

### V1000 Hydraulic Control Valves – Dimensions and Weights

p	1" In-Line (25 mm)	1½" In-Line (40 mm)	2" In-Line (50 mm)	2" Angle (50 mm)
	(mm)	(mm)	(mm)	(mm)
L	110	160	170	85
H	115	180	190	210
R	22	35	38	60
W	78	125	125	125
Weight (kg)	0,35	1,00	1,10	0,91

*In-line*



*Angle*



V1000 Hydraulic Control Valves – Flow Chart

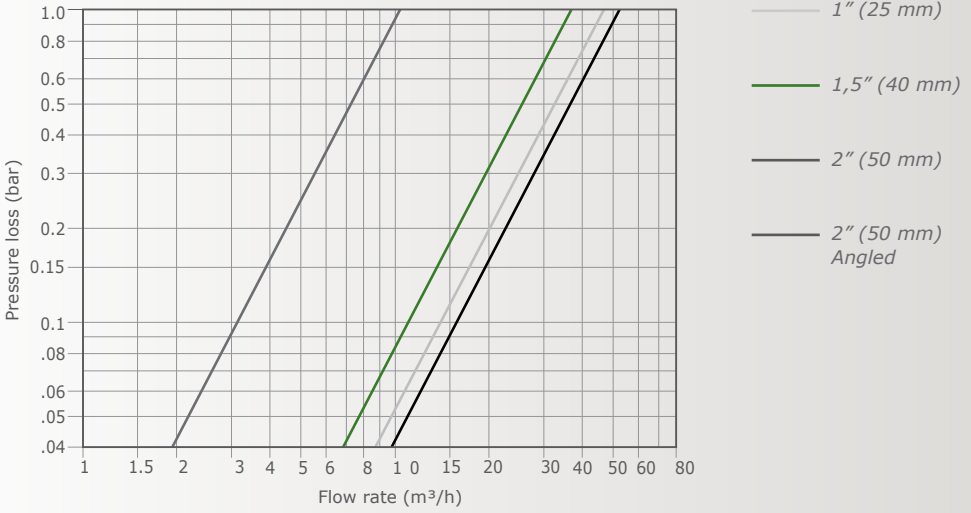



*Engineered to optimize to maximize flow capacity, reduce pressure loss, and resist cavitation.*

## V2000 Hydraulic Control Valve

The Rivulis V2000 Hydraulic Control Valves are designed to meet the needs of multiple applications in your irrigation system, including simple control (on/off), pressure reducing, and quick relief. The valve operates by responding to pressure and flow changes with a diaphragm piston assembly. The body design has been optimized to maximize flow capacity, reduce pressure loss, and resist cavitation.

The V2000 will be the primary choice for agricultural irrigation applications requiring high flows at low pressures and low flows at high pressures. Because the valves are made with glass-filled nylon, they resist damage from chemicals and have long term durability. The V2000 Hydraulic Control Valve line is offered with a wide range of options including size, end connections (threaded, flanged, PVC glued, or grooved), actuation method (electric, hydraulic), and pilots and springs. Accessories and parts can be ordered to build customized valves.



### Product Information

- Straight-thru flow design
- Wide operating range
- Various end connections
- Nyglass construction
- Electric / Hydraulic / Manual
- Manual throttling up to 3 inch
- Manual override switch included with electric valves



### Product Options

- Valve Applications: On/Off, Pressure Reducing, Pressure Sustaining, and Quick Relief
- Sizes: 2" to 6"
- Connections: Threaded, Flange, or Grooved



### Operating Guidelines

- Operating Pressure Range: 0,5–10 bar
- Maximum Pressure Rating: 10 bar

**V2000 Hydraulic Control Valve – Configuration Options**

Actuation	Options	Pre-Set Pressure (bar)	On-Off		Pressure Reducing			Quick Relief Auto
			Manual	Electric	Manual	Electric	Hydraulic	
Control Circuit / Pilot	No Pilot		V	V				
	0,5–3,0 bar, 2/3-way	0,8			V	V	V	
	0,8–6,5 bar, 3-Way	2,5			V	V	V	
	1,0–12,0 bar, 2-Way	5,0						V
Solenoid	12 Volt DC – Latch			V		V		
	24 Volt AC – Normally Closed			V		V		

**V2000 Hydraulic Control Valve – Dimensions and Weights**

Dimension	2" Thread (50 mm)	2" L Thread (50 mm) L	3" Thread (80 mm)	3" Flange (80 mm)	3" L Thread (80 mm) L	3" L Flange (80 mm) L	4" Flange (100 mm)	6" Flange (150 mm)
	(mm)	(mm)	(mm)	(mm)	(mm)	(mm)	(mm)	(mm)
L	230	298	298	308	298	310	350	480
H	185	195	195	255	240	280	290	285
R	40	50	50	100	60	100	112	145
W	135	135	135	200	190	200	224	385
Weight (kg)	1,35	1,6	1,6	2,5	3,0	4,0	4,9	12,5

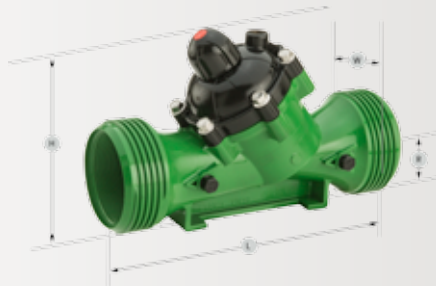

V2000 Hydraulic Control Valves – Flow Chart

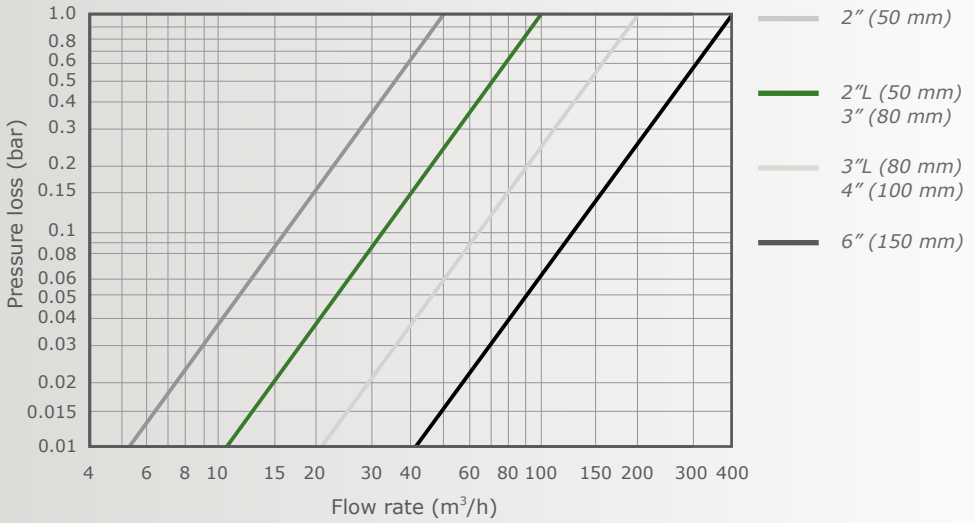



*Engineered to optimize to maximize flow capacity, reduce pressure loss, and resist cavitation.*

## V3000 Hydraulic Control Valve

The V3000 Hydraulic Control Valves are constructed with several key features that provide long term durability under a variety of tough applications. And the valves are designed to operate under high pressure and high flow rates. The diaphragm piston assembly uses an innovative method to create a seal against the body of the valve and is carefully balanced and supported to avoid distortion; resulting in long-life and controlled actuation even under harsh conditions. The V3000 are made of metal bodies and covers and assemble with just 4 bolts, reducing the time it takes for maintenance.



### Product Information

- Metal construction
- Electric / Hydraulic / Manual
- Wide operating range
- 2" – 10" valve sizes
- Various end connections
- Solid one piece diaphragm piston assembly
- Manual override switch included with electric valves.



### Product Options

- Valve Applications: On/Off, Pressure Reducing, Pressure Reducing and Sustaining, and Quick Relief
- Sizes: 2" to 10"
- Connections: Threaded, Flanged, or Grooved



### Operating Guidelines

- Operating Pressure Range: 0,5–16 bar
- Maximum Pressure Rating: 16 bar (2"-10 valve body)
- Maximum Pressure for 2-4" with plastic pilot max: 10,0 bar
- Maximum Pressure for 6-10" with metal pilot: 16 bar

### V3000 Hydraulic Control Valve – Configuration Options

Actuation	Options	Pre-Set Pressure (bar)	On-Off		Pressure Reducing		Pressure Reducing and Sustaining Manual	Quick Relief Auto
			Manual	Electric	Manual	Electric		
Control Circuit / Pilot	No Pilot		V	V				
	0,8–6,5 bar, 3-Way	2,5			V	V	V	
	1,0–12,0 bar, 2-Way	5,0						V
Solenoid	12 Volt DC – Latch			V		V		
	24 Volt AC – Normally Closed			V		V		

### V3000 Hydraulic Control Valve – Dimensions and Weights

Dimension	2" Thread (50 mm)	3" Thread (80 mm)	3" Flange (80 mm)	4" Flange (100 mm)	6" Flange (150 mm)	8" Flange (200 mm)	10" Flange (250 mm)
	(mm)	(mm)	(mm)	(mm)	(mm)	(mm)	(mm)
L	180	255	250	320	415	500	605
H	114	165	210	242	345	430	460
W	119	170	200	223	306	365	405
R	39	55	100	112	140	170	202
Weight (kg)	4	13	19	28	68	125	140

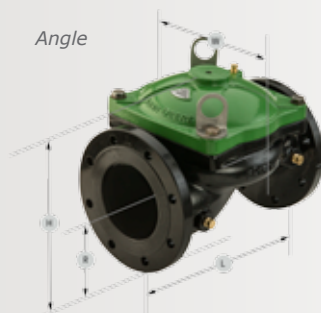

V3000 Hydraulic Control Valve – Flow Chart

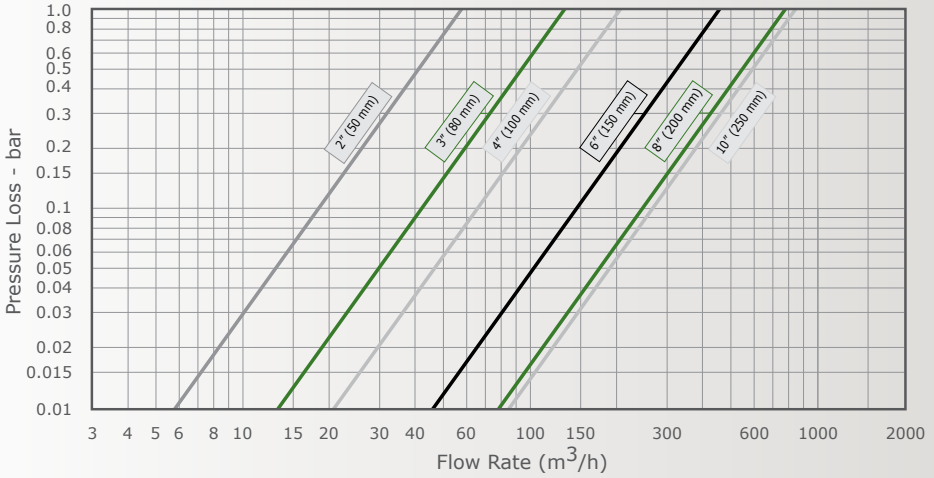



# Rivulis

Irrigation



[Rivulis.com](https://www.rivulis.com)

This literature has been compiled for worldwide circulation and the descriptions, photos, and information are for general purpose use only. Please consult with an irrigation specialist and technical specifications for proper use of products. Because some products are not available in all regions, please contact your local dealer for details. Rivulis Irrigation reserves the right to change specifications and the design of all products without notice.